

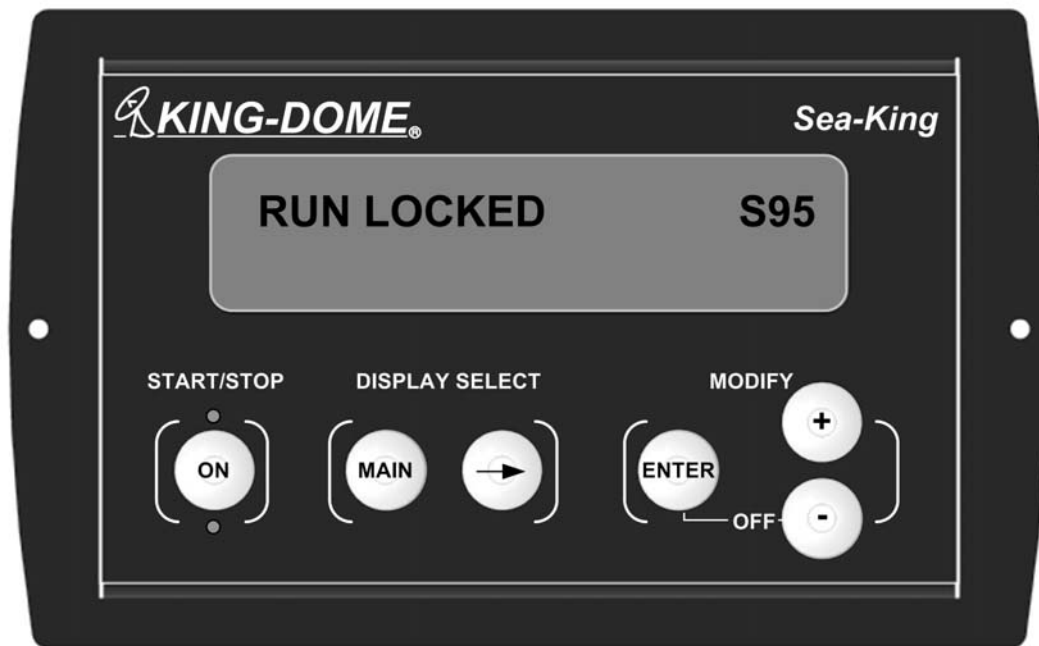

# Sea-King Fully Stabilized Marine Satellite System

## 9762-SW

### Installation and Operating Instructions



*Satellite Solutions for Mobile Markets*

11200 Hampshire Avenue South, Bloomington, MN 55438-2453  
Phone: 800-982-9920 Fax: 952-922-8424

[www.kingcontrols.com](http://www.kingcontrols.com)



## IMPORTANT!

The satellite TV market is expanding and changing. The information in this manual was accurate at the time of printing. If your Sea-King System does not operate as outlined in this manual please call King Controls at 1-800-982-9920 or visit our website at [www.kingcontrols.com](http://www.kingcontrols.com).

## TABLE OF CONTENTS

Section	Contents	Page
1.	INTRODUCTION.....	2
2.	DEFINITION OF TERMS .....	3
3.	INSTALLATION .....	4-17
4.	OPERATION .....	18-21
5.	TROUBLESHOOTING .....	22-25
6.	MAINTENANCE .....	26
7.	LIMITED WARRANTY .....	27

### ELECTRICAL HAZARD WARNING!

The coaxial cable that connects the dome unit to the tuner carries a 24 volt electrical current. Exercise extreme caution when handling this cable. Do not cut, break, or splice this line. Do not insert or connect any devices such as splitters or any other device for any reason. This line is not compatible with any other equipment. Damage will occur to any device other than the dome unit if connected to the antenna port on the tuner.

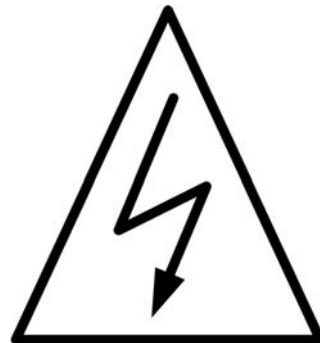

DIRECTV® is an official trademark of DIRECTV, division of GM Hughes Electronics Corporation.

Dish Network® is an official trademark of Echostar Communications Corporation.

Bell ExpressVu® is an official trademark of Bell Canada.

DVB® is a trademark of the DVB Digital Video Broadcast Project (1991-1996)

The Sea-King Fully Stabilized Marine Satellite System includes 5 main components. (**Fig. 1**)

Dome (Antenna) Unit	Mounted on the vessel. The dish is covered by a protective dome that keeps operational components free from the elements.
Controller	Located in the vessel. Used to activate and monitor the system, and access programming and diagnostic information.
Tuner	Located in the vessel. Decodes the satellite signal so the Sea-King locks onto and tracks the correct satellite.
De-stacker	Located in the vessel. Splits the “dual” signal from the LNB.
Power Supply	Located in the vessel. Supplies proper operating voltage to the Sea-King.

Note: A TV, satellite receiver, and program subscription are also required for satellite TV viewing. (Not supplied by King Controls.)

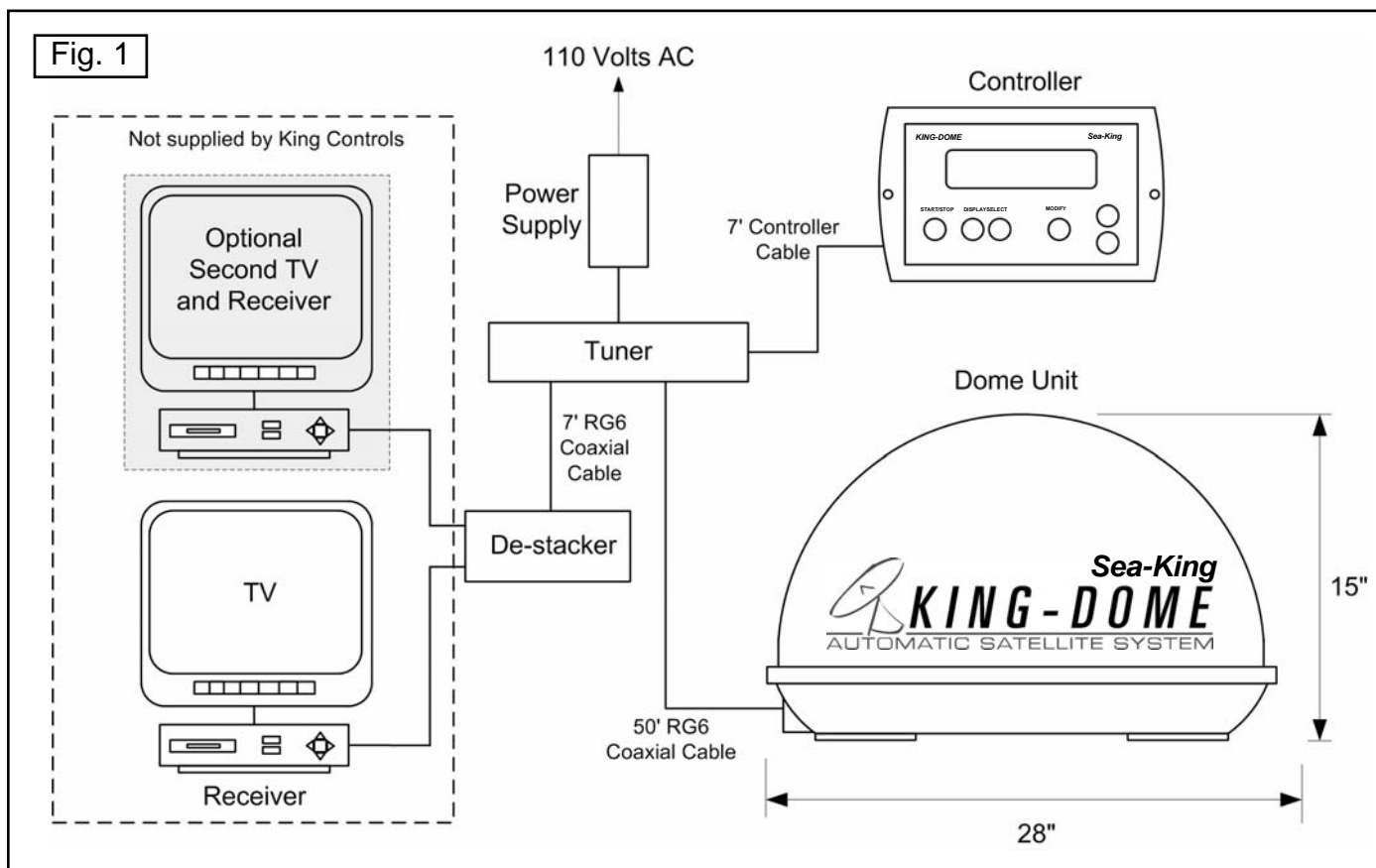

**AZIMUTH:** Angle in degrees measured clockwise from Magnetic North ( $0^\circ$ ). (Fig. 2)

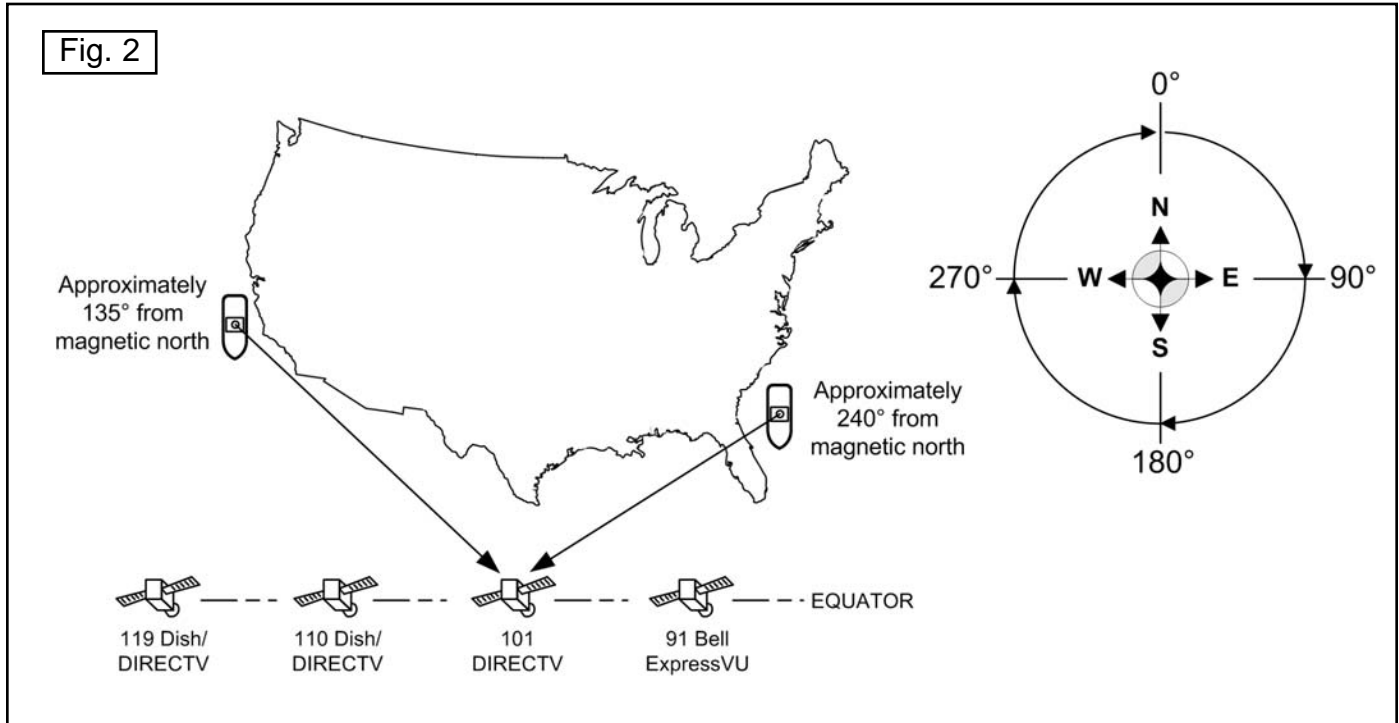

**ELEVATION:** Angle in degrees measured from the ground plane. (Fig. 3)

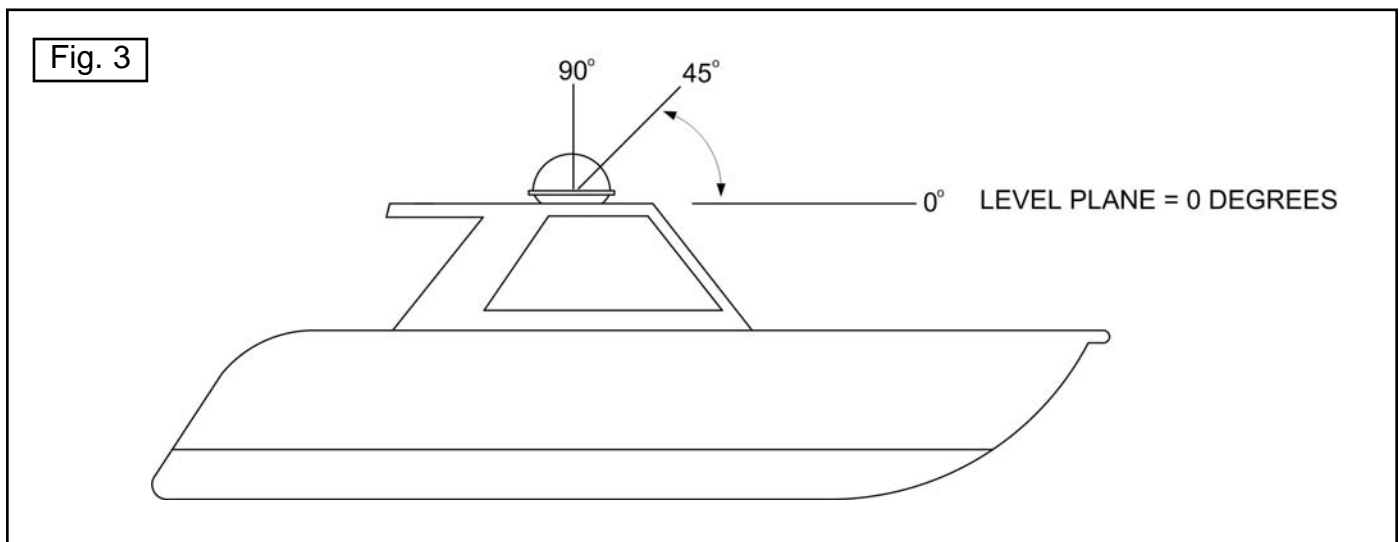

**SIGNAL STRENGTH:** Intensity of electronic signal received from the satellite transmission.

## TOOLS AND MATERIALS REQUIRED:

- drill and drill bit set
- tape measure
- 7/16" open end wrench (coax connections)
- adhesive sealant (compatible with vessel material)
- appropriate fasteners to install all components and wiring
- 5/32" allen wrench, channel lock or pliers (to remove shipping bolt)
- wire cutter (to remove shipping tie strap)

## KIT CONTENTS:

1. Unpack and identify all components. (Fig. 4)

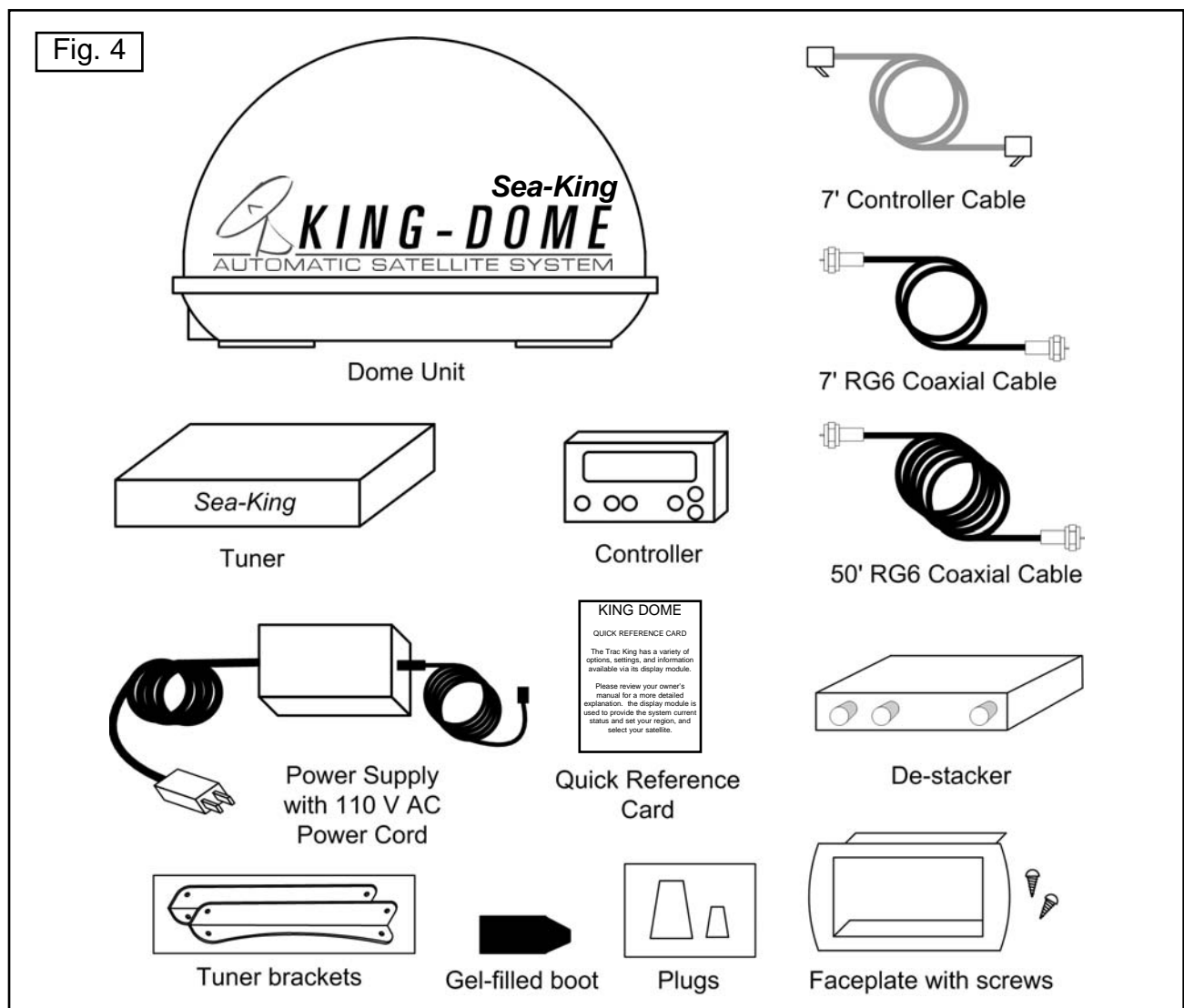

**IMPORTANT!** The tie strap and spacer, and the bolt and washer must be removed from the bottom of the dome unit prior to installation. **DO NOT REMOVE THE DOME COVER TO REMOVE THESE SHIPPING RESTRAINTS.**

**YOU MUST PLUG THE TWO HOLES WITH THE SUPPLIED PLUGS.**

2. Remove and discard the tie strap and spacer, and the bolt and washer that pass through the bottom of the base. **(Fig. 5)**

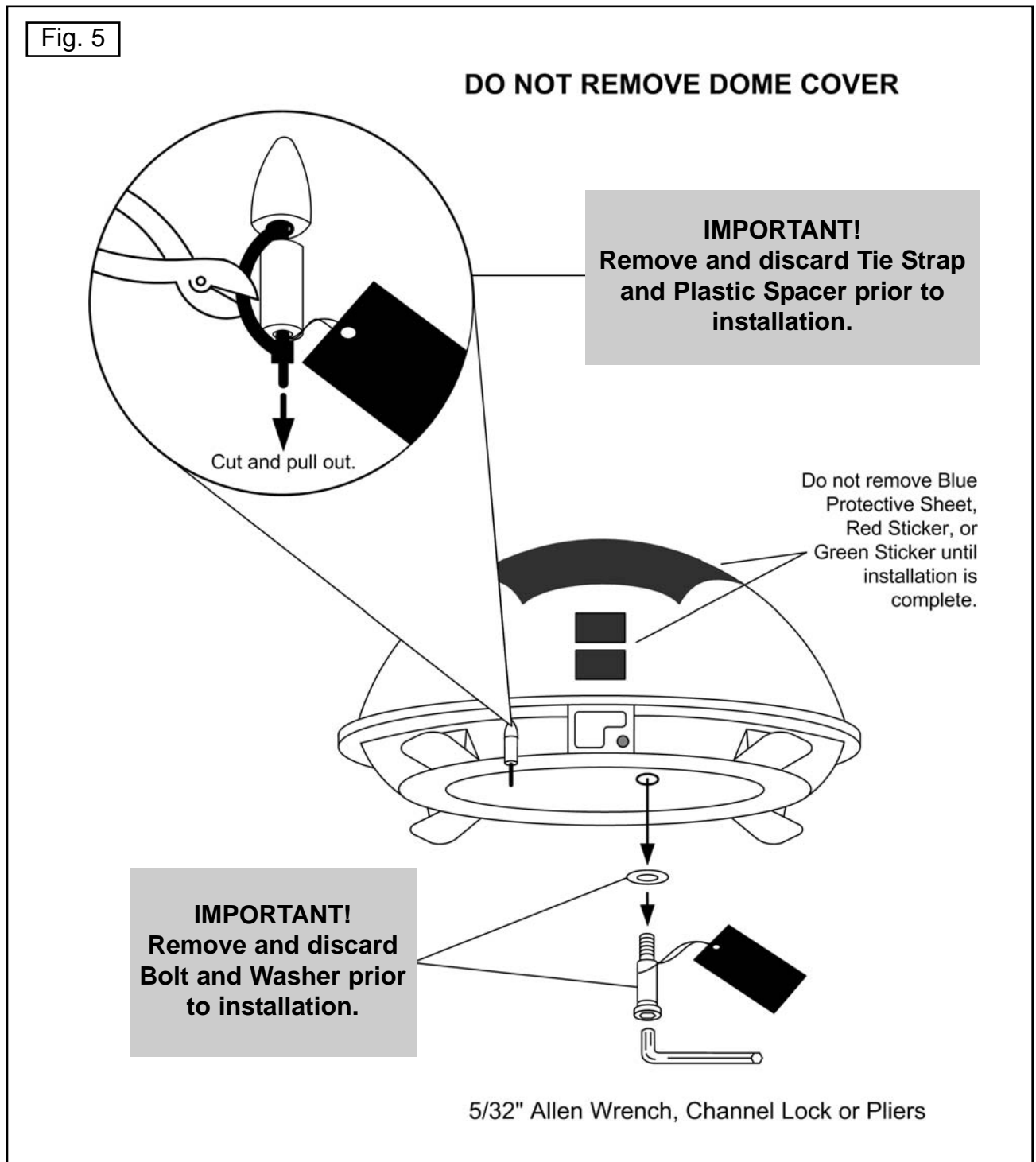

3. Insert provided plugs into holes that were occupied by tie strap and shipping bolt. **(Fig. 6)**

Fig. 6

**IMPORTANT!**  
After removing shipping restraints, firmly insert plugs into appropriate holes. Plugs should be almost flush with base.

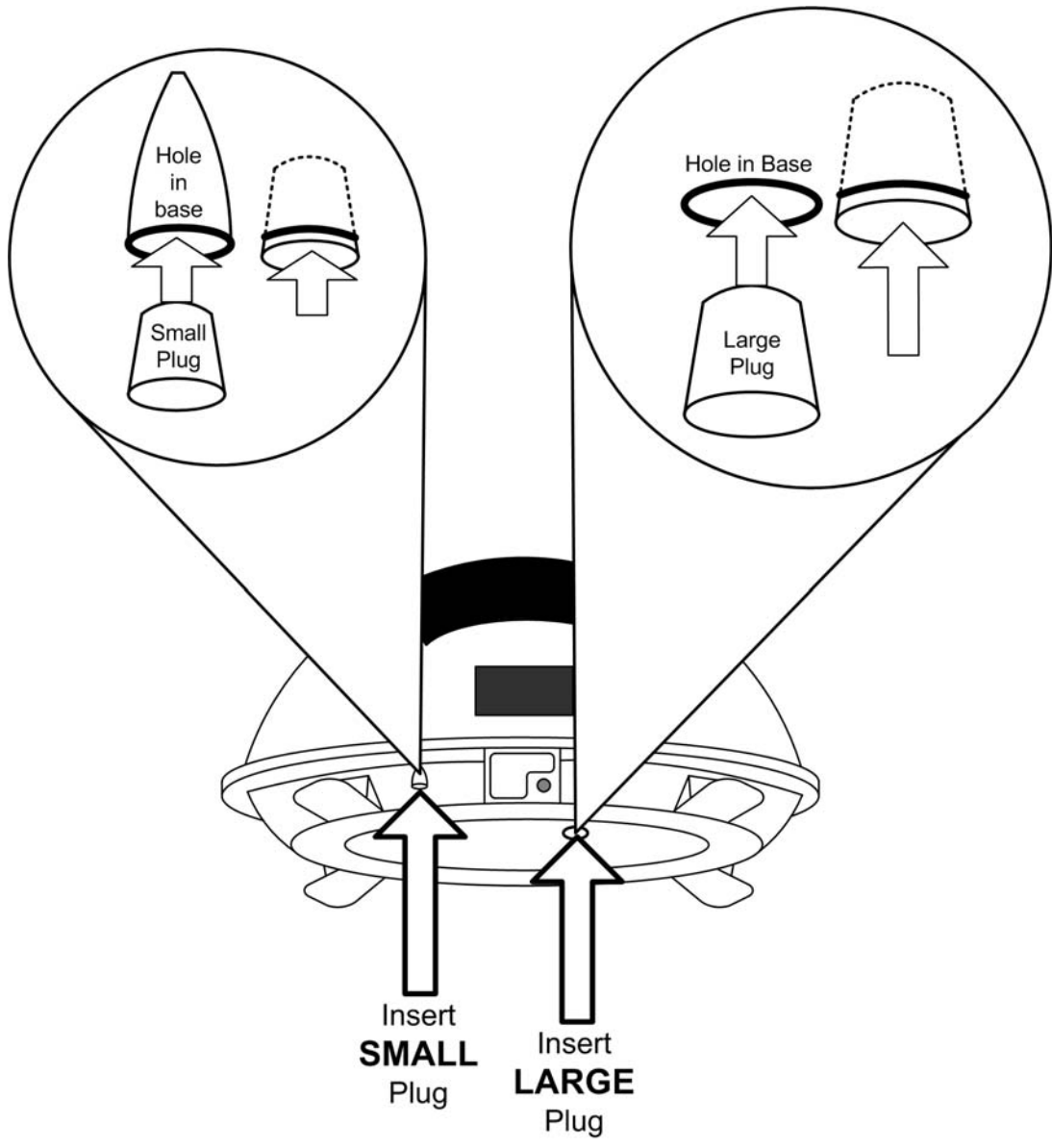

## DOMES LOCATION

1. Select an area on the vessel for the dome unit, and the location where the coax cable will enter the vessel through the surface to the satellite receiver and internal components. Use the following criteria:
  - a) The shortest distance between the dome unit and the satellite receiver is most desirable.
  - b) The dome unit requires a 28 inch diameter circle or an appropriate mounting bracket such as the King Controls Radar Arch Mount #9745.
  - c) The dome should never be mounted so that it is tilted more than two degrees in any direction.
  - d) Keep the dome unit as far away from the radar as possible.
  - e) There must be no “line of sight” obstructions from this location. Items such as masts or radar antennas that are too close to the dome unit may prevent the satellite signal from reaching the dish. **(Fig. 7)**

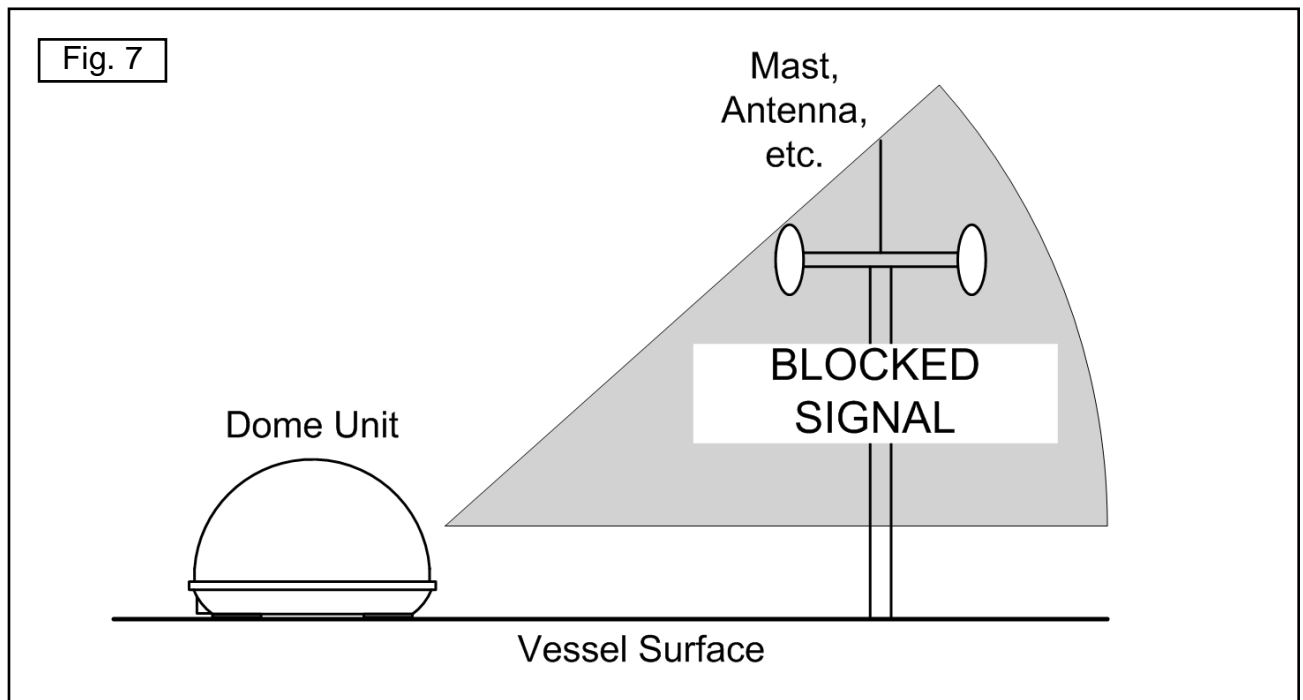

**IMPORTANT! Make sure shipping restraints are removed from bottom of dome unit. (Fig. 5, Page 5)**

2. Place the dome unit in the selected area.

## COMPONENT LOCATION:

1. Select the location of the internal components using the following criteria:
  - a) The Controller, Tuner, Power Supply and De-stacker should be in the same general vicinity of the satellite receiver, **AND ACCESSIBLE FOR OPERATION AND MAINTENANCE PURPOSES.**
  - b) The Tuner should not be stacked directly on top of other electronics. If located in a cabinet or other enclosure, make sure there is adequate ventilation around the unit. (If using the Tuner mounting brackets see page 17.)
  - c) The Controller should be conveniently located for the end user. (If using the Wall Mount Faceplate, see page 16.)
  - d) All components should be secured so they do not shift or bounce around during vessel motion.
2. Place the components in the selected areas.

## SYSTEM LOCATION CHECK

**ELECTRICAL HAZARD WARNING!**

The coaxial cable that connects the dome unit to the tuner carries a 24 volt electrical current. Exercise extreme caution when handling this cable. Do not cut, break, or splice this line. Do not insert or connect any devices such as splitters or any other device for any reason. This line is not compatible with any other equipment. Damage will occur to any device other than the dome unit if connected to the antenna port on the tuner.

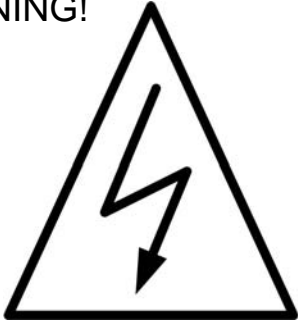

## AVOID SHARP BENDS WHEN ROUTING COAX!



NOT CORRECT



CORRECT

To verify proper operation of the components in their selected locations, perform a System Location check as follows:

1. Connect system as outlined in **Fig. 10, Page 13.**
2. Verify system operates properly as described in **Section 4 OPERATION, Page 18.**
3. Disconnect all components.

## DOMESTIC INSTALLATION AND EXTERNAL WIRING

**IMPORTANT!** Use only the coaxial cables supplied with the Sea-King. Do not cut coax. Coil and store excess cable in the cabinet with the components.

If coaxial cable other than that supplied with the Sea-King is used, the following guide lines must be followed:

- 1) Cable must be rated at 2.2 Ghz or higher.
- 2) Ends must be terminated with radial F-connectors as in Fig. 8.

Fig. 8

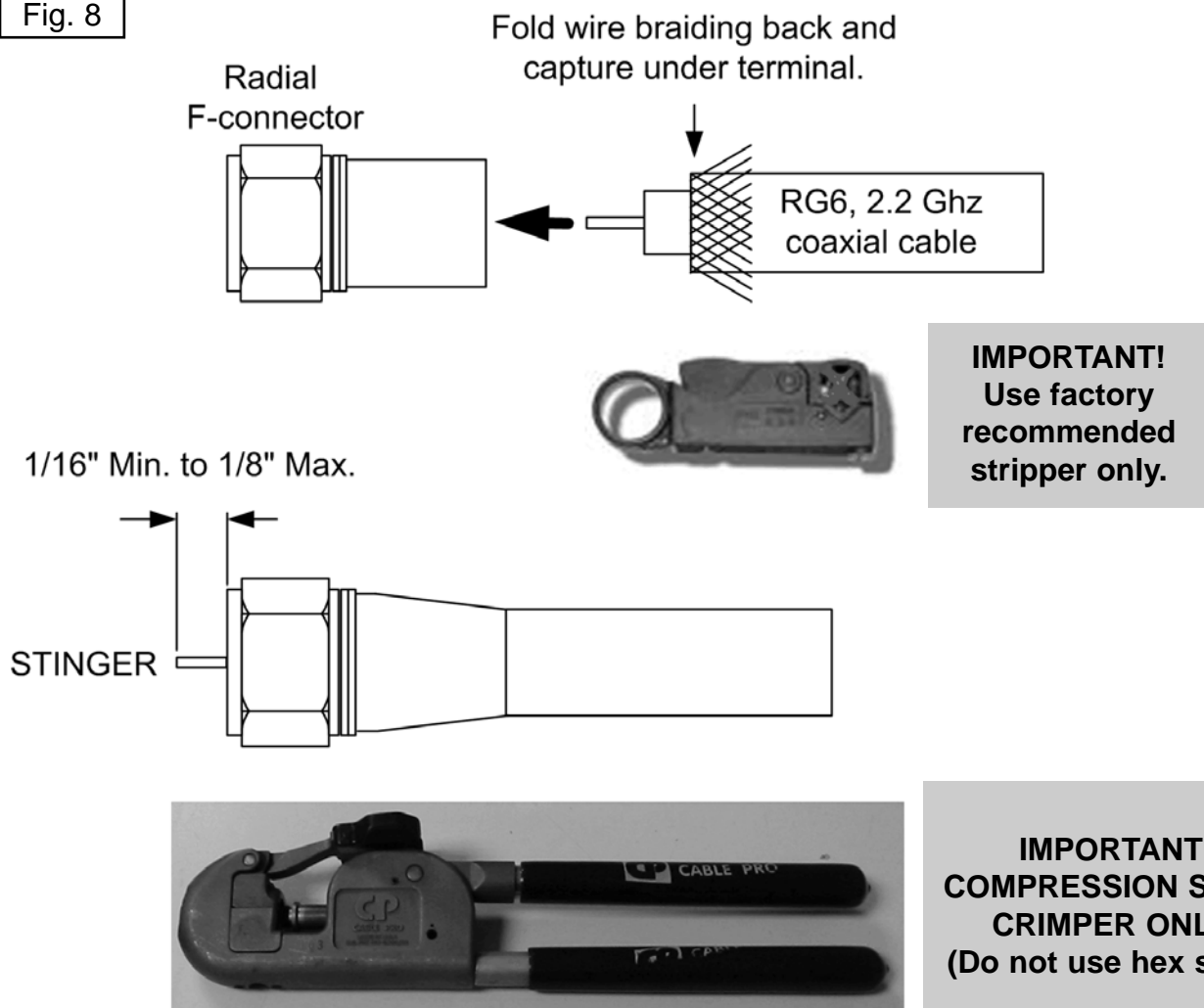

Note. Apply non-conductive electrolytic grease to all stingers before installation.

Note: The installer is responsible for determining the most appropriate fastener to secure the dome unit to the vessel surface. Depending on the surface material, fasteners such as lag screws, well nuts, sheet metal screws, toggle bolts and T anchors may be used, and should always be used in combination with a surface compatible adhesive sealant.

The installer is responsible for weatherproofing all holes with sealant.

**IMPORTANT! Make sure power supply is disconnected from 110 volt source before continuing with permanent installation.**

**Make sure shipping restraints are removed from bottom of dome unit, and plugs inserted in appropriate holes. (Fig. 5, Page 5 and Fig. 6, Page 6)**

**Cable connection must ALWAYS be positioned facing the rear of vessel.**

1. Mount the dome unit. Use the pre-drilled holes in the mounting feet as a guide to install the fasteners into the vessel surface. Use additional fasteners whenever necessary.
2. Test that the dome unit is secure by pulling upward from each foot location.

Note. Apply non-conductive electrolytic grease to all stingers before installation.

3. Connect 50' coax cable to the coax port located on the back of the dome unit and tighten connection. **DO NOT OVER TIGHTEN CONNECTION. (Fig. 9)**
4. Snap the gel-filled boot around the coax connection so that it is flush against the back of the dome unit. **(Fig. 9)**

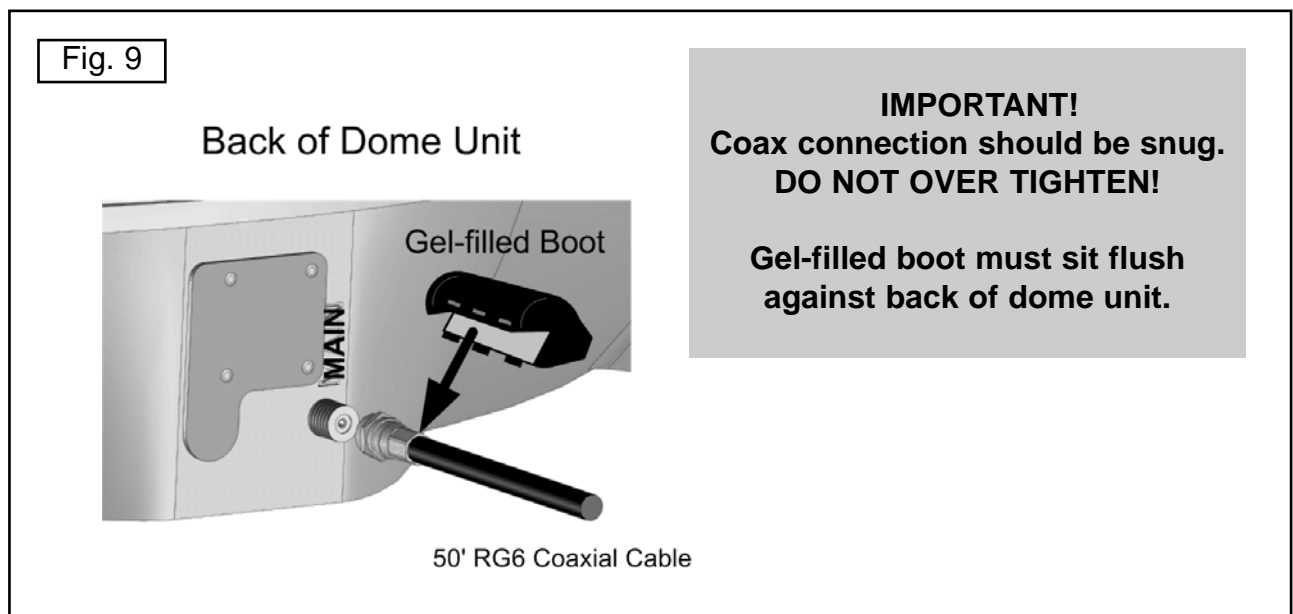

## AVOID SHARP BENDS WHEN ROUTING COAX!



NOT CORRECT



CORRECT

5. Run coax from the dome unit to the location where coax will enter the vessel. Secure coax every 12-18 inches.
6. Drill 1/2" hole into the vessel where the tuner will be located. Feed coax down through hole. Seal opening with compatible sealant so that it is entirely waterproof (inside and outside of the 1/2" hole).
7. Remove blue protective sheet, red "position to rear" sticker and green "De-stacker" sticker from the dome unit.

## ELECTRICAL HAZARD WARNING!

The coaxial cable that connects the dome unit to the tuner carries a 24 volt electrical current. Exercise extreme caution when handling this cable. Do not cut, break, or splice this line. Do not insert or connect any devices such as splitters or any other device for any reason. This line is not compatible with any other equipment. Damage will occur to any device other than the dome unit if connected to the antenna port on the tuner.

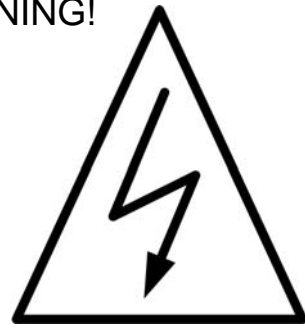

### INTERNAL WIRING (Fig. 10)

Note. Apply non-conductive electrolytic grease to all stingers before installation.

1. Connect the 50' coax cable from the dome unit to the tuner port labeled "ANT."
2. Connect the 7' coax from the tuner port labeled "REC" to the de-stacker port labeled "INPUT."
3. Connect the 7' controller cable from the controller to the tuner port labeled "IDD."
4. Connect the port on the de-stacker labeled "IRD Output 1" to the "SAT IN" port on the first satellite receiver. (Optional: Connect the port on the de-stacker labeled "IRD Output 2" to the "SAT IN" port on the second receiver.)
5. Connect the power supply cable to the tuner port labeled "PWR".
6. Plug the power supply into a 110 VAC source.

Note: The controller should turn on for 3 seconds and then turn off. If the controller stays on, press the ENTER and "-" button simultaneously for 3 seconds to turn unit off.

Fig. 10

# INTERNAL WIRING

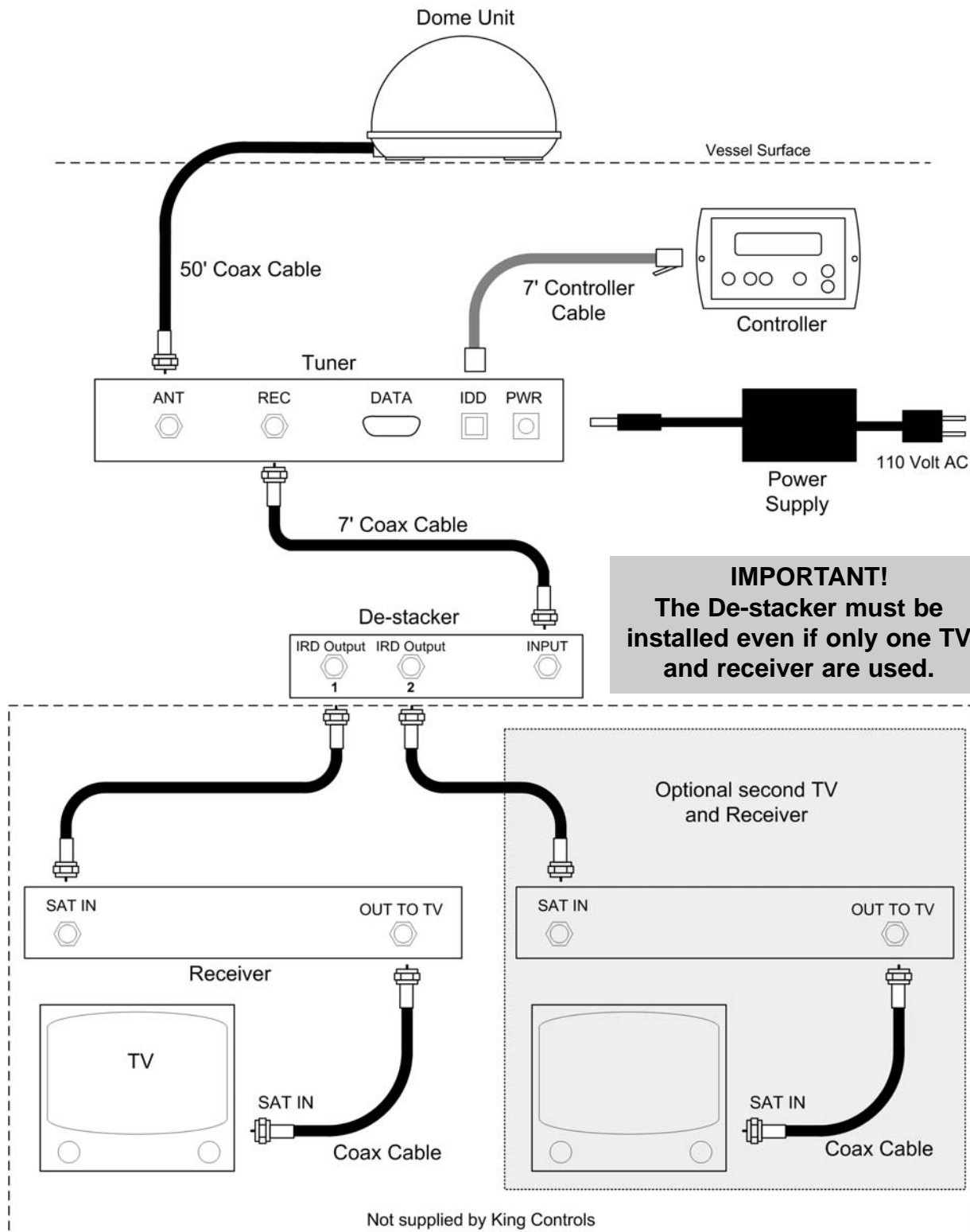

**IMPORTANT! AVOID SHARP BENDS WHEN ROUTING COAX.**

## MULTIPLE SATELLITE RECEIVER CONFIGURATIONS

With the use of a Multi-switch (not supplied by King Controls), more than two TV's and receivers can be hooked up. (see **Fig. 11** for typical 4 receiver hookup)

Other options:

3-4 satellite receivers: use one 2x4 or 3x4 multi-switch

8 satellite receivers: use one 2x8 or 3x8 multi-switch

16 satellite receivers: use one 3x16 multi-switch

Recommended multi-switches (other brands may work as well)

2x4: Terk brand

3x4: RCA D6520 or Perfect 10 PVMS-4EP

3x8: Perfect 10 PVMS-8EP

Fig. 11

### TYPICAL 4 RECEIVER HOOKUP

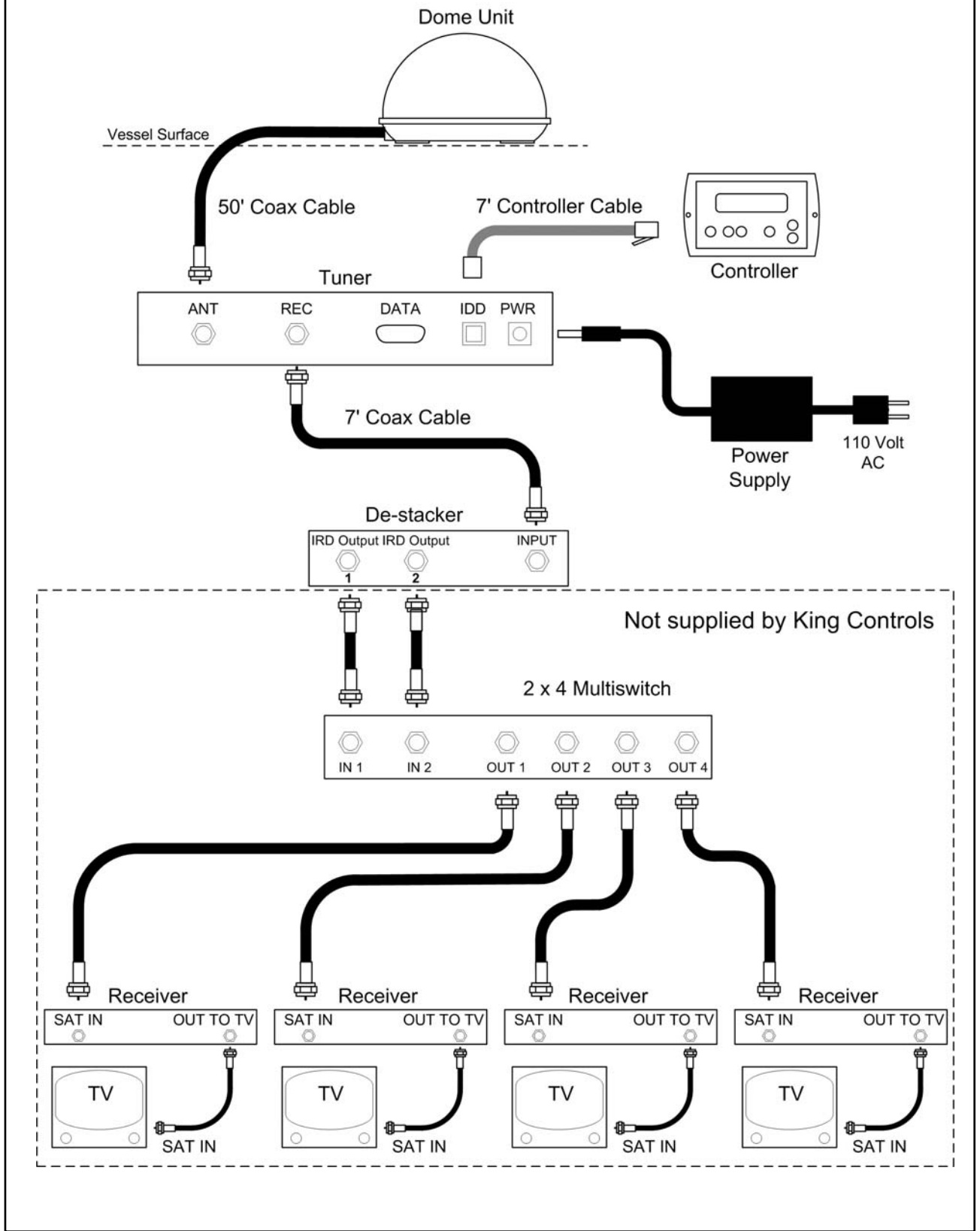

## OPTIONAL WALL MOUNT FACEPLATE (INCLUDED)

1. Use the Faceplate as a template to mark and cut out the mounting cavity, and if necessary, mark and drill the mounting holes. **(Fig. 12)**

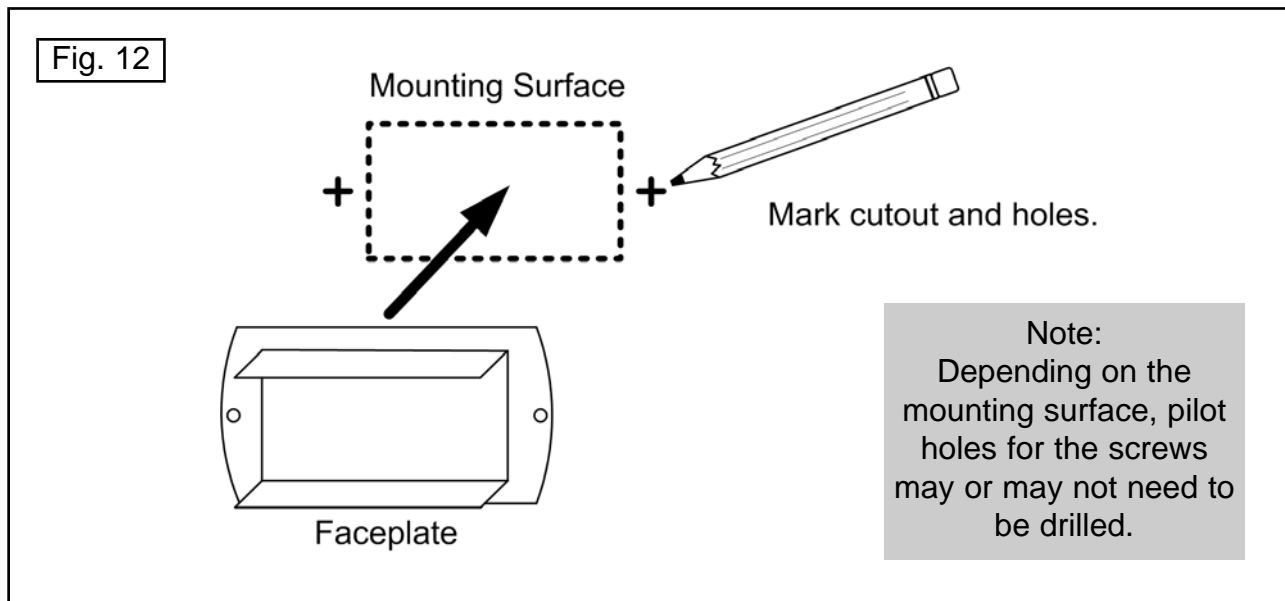

2. Remove 4 screws from Controller. **(Fig 13)**
3. Slide Faceplate over Controller.
4. Replace 4 screws.
5. Mount Faceplate in wall with supplied screws.

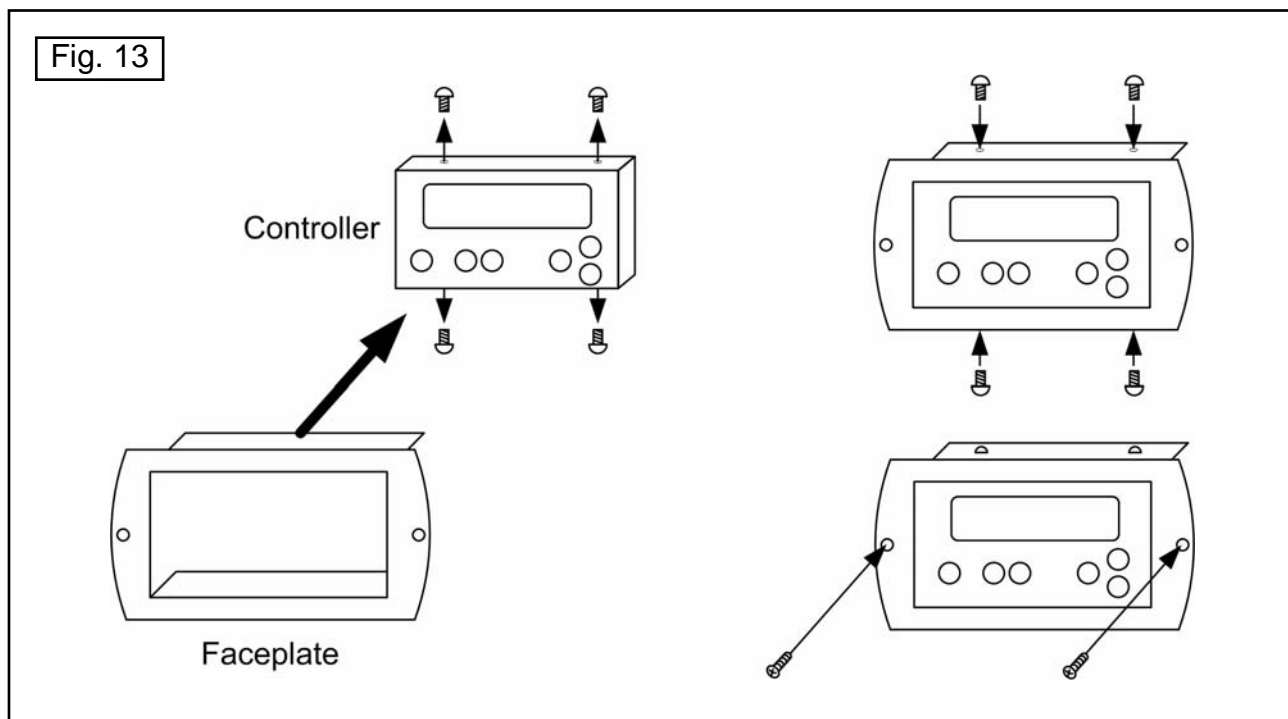

## OPTIONAL TUNER MOUNTING BRACKETS (INCLUDED)

1. Remove 4 screws from the tuner.
2. Fasten mounting brackets to tuner with same screws. **(Fig. 14)**

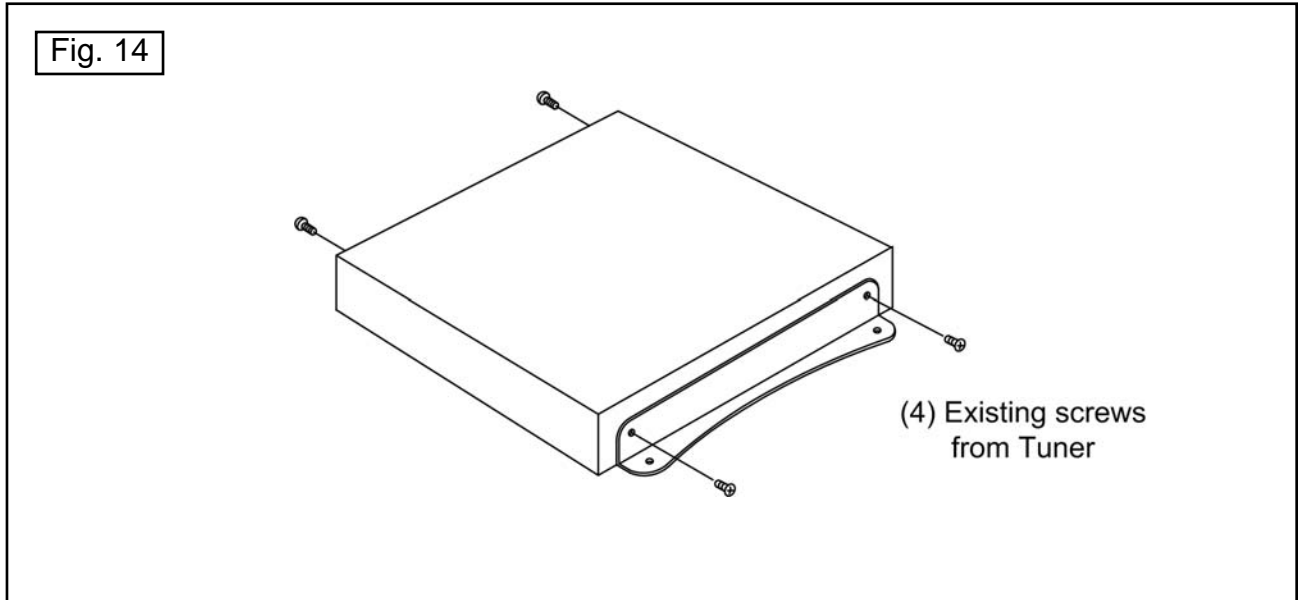

Note: The installer is responsible for determining the most appropriate fasteners to secure the mounting brackets to the chosen surface.

3. Mount tuner in previously chosen location. **(Fig 15)**

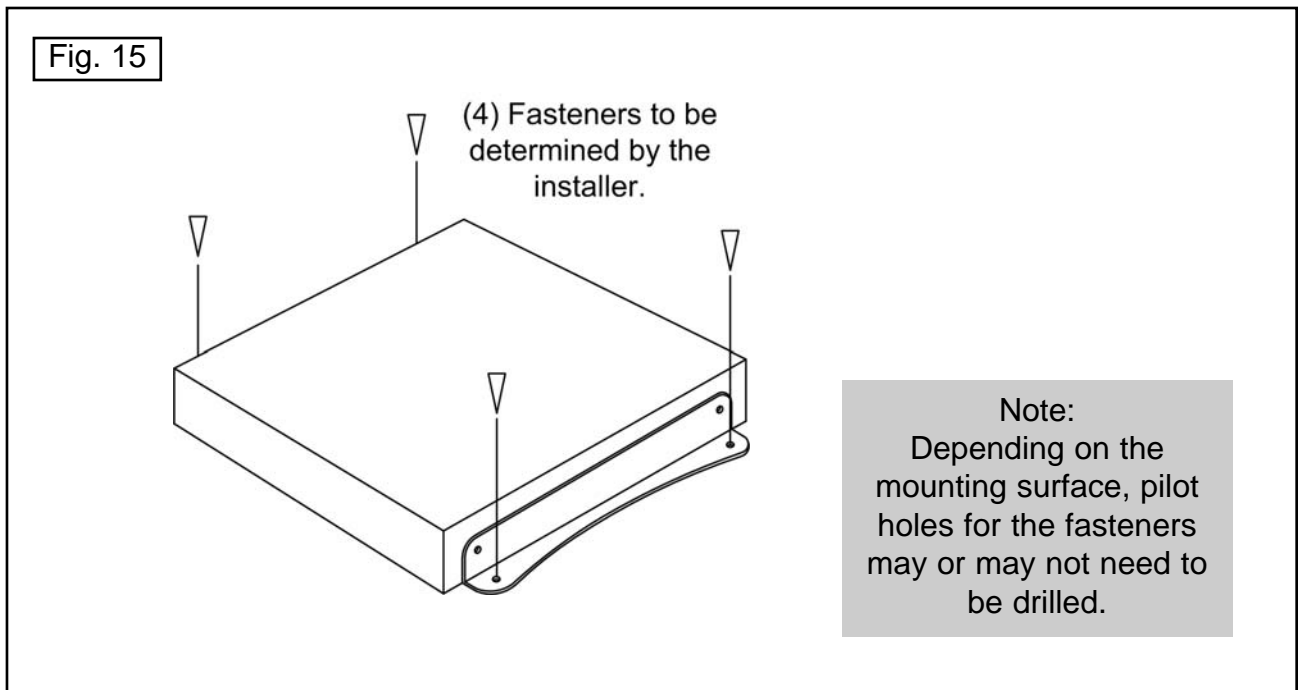

# SECTION 4      OPERATION

**IMPORTANT!** There must be a clear “line of sight” to the satellite. (See Fig. 2, Page 3) Terrain, other boats, buildings, trees, masts, telephone poles, etc. can all block the satellite signal from reaching the dish.

Note: This example is for the DTV 101 satellite in Region 2-North Central. The information on your controller will vary depending on the satellite and region you have chosen.

1. Turn on TV and satellite receiver. “Searching for Satellite Signal” or similar should appear on TV.

2. Press 



Unit powers up, performs a self-diagnostic and loads software.

**POWER UP  
PLEASE WAIT**

**LOADING  
PLEASE WAIT**

Unit begins searching for the selected satellite.

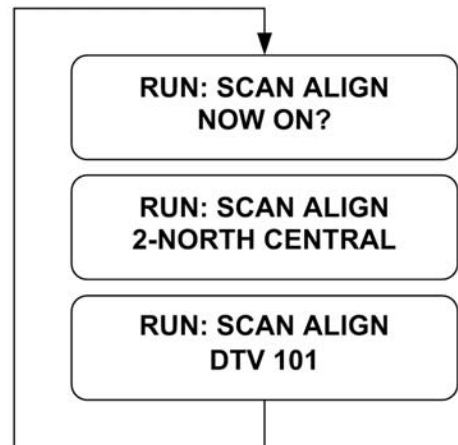



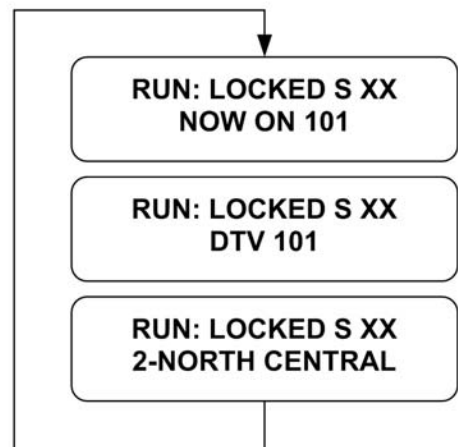







Unit has locked onto the selected satellite.

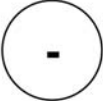

Note: The Sea-King must remain powered on to maintain a signal. If you are going to be stationary and wish to continue watching TV, **DO NOT TURN THE SYSTEM OFF.**

Note: To reduce satellite acquisition time, you can set your current region.

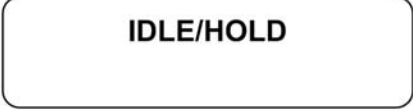
## SET REGION (OPTIONAL)

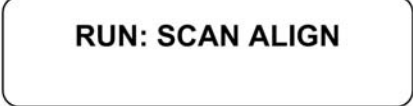
1. Press  Unit goes into IDLE/HOLD mode. 
2. Press  Unit goes into USER SETUP menu. 
3. Press  Unit goes into SET REGION menu. 
4. Press  or  Find your location on the map below and determine which region you are in. Use the plus and minus buttons to display your region on the controller. 
5. Press  Sets REGION into memory. 
6. Press  Unit searches based on new REGION. 

### REGION OPTIONS:

- 1 NORTH WEST
- 2 NORTH CENTRAL
- 3 NORTH EAST
- 4 CENTRAL WEST
- 5 MIDDLE CENTRAL
- 6 CENTRAL EAST
- 7 SOUTH WEST
- 8 SOUTH CENTRAL
- 9 SOUTH EAST
- ALL REGIONS
- 0 RECALIBRATE

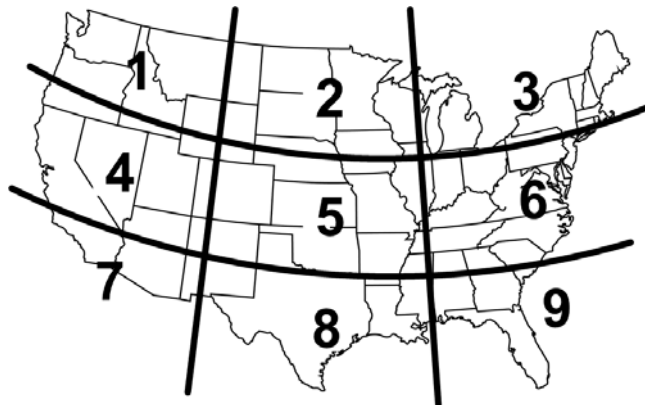

## SET SATELLITE SERVICE

SATELLITE OPTIONS	
DTV 101	DIRECTV at 101 West Longitude
DTV 119	DIRECTV at 119
DTV 101/119	DIRECTV at 101 and 119
DISH 110	Dish Network at 110
Dish 119	Dish Network at 119
Dish 148	Dish Network at 148
EXPVU 82	Bell ExpressVu at 82
EXPVU 91	Bell ExpressVu at 91

Note: Future locations can be added.



Unit goes into SET SATELLITE menu..

**SET SATELLITE**

-----?-----

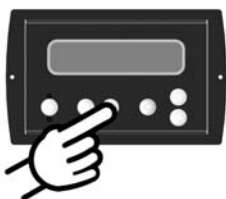

or

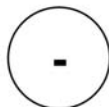

Use the plus and minus buttons to display your desired satellite on the controller.

**Display desired  
satellite on controller.**



Sets satellite in memory.  
Unit moves to new designated satellite.

**RUN: SWITCHING**

**RUN: LOCKED**  
Displays chosen satellite

Note: **For DIRECTV Subscribers:** The satellite setting allows the user to select the satellite and service provider of choice. For DIRECTV subscribers, the Sea-King can also track a secondary or alternate satellite.

Example: If you are a subscriber to the DIRECTV service most of the programming that you will be watching will be transmitted from the satellite located at 101 degrees. You may also subscribe to programming that is transmitted from another satellite located at 119 degrees. In order to receive programming from both satellites you can either select an individual (DTV 101) satellite manually from the display or you can select a multiple (DTV 101/119) satellite setup. The multiple satellite selection will automatically switch between satellites (DTV 101/119) based on the channel or programming that you select on the Satellite Receiver (multi-satellite capable receiver is required). Please keep in mind that the programming may pause (freeze frame) or pixelate while the antenna acquires and locks onto the new satellite.

The multiple satellite setting will work only if your satellite receiver is set up to work in oval dish mode. Consult your satellite receiver manual for instruction.

It is not recommended to use the DTV 101/119 setting unless there is programming on the DTV 119 satellite that you specifically subscribe to.

Note: **For DISH NETWORK Subscribers:** Use the procedure on the previous page to switch between the 110 and 119 satellites.

SYMPTOM	POSSIBLE SOLUTION
Controller does not power up.	<p>Check: tuner is connected to power supply.</p> <p>controller is connected to tuner.</p> <p>power supply is plugged into 110 VAC outlet.</p>
Controller remains in "Power Up, Please Wait" condition.	<p>Disconnect power supply for 15 seconds, then reconnect.</p> <p>Verify voltage on coax at dome unit is 24 volts.</p> <p>Inspect rotary joint cable, then reseal. (inside dome unit)</p> <p>Inspect all coax cables and verify connections are snug but not overly tight. (inside and outside dome unit)</p>
Controller displays "Load Error."	<p>Disconnect power supply for 15 seconds, then reconnect.</p> <p>Inspect rotary joint cable, then reseal. (inside dome unit)</p>
Controller displays "AZ FAULT."	<p>Dish cannot rotate.</p> <p>Verify shipping bolt is removed. (bottom of dome unit)</p> <p>Disconnect power supply for 15 seconds, then reconnect.</p> <p>Perform <b>OPTION 21 RE-INITIALIZE and 0-RECALIBRATE</b>. (pages 24-25)</p> <p>Reseat ribbon cables. (inside dome unit)</p>
Display reads "EL FAULT."	<p>Dish stuck on limit switch.</p> <p>Make sure shipping tie strap is removed. (back left hand side of dome unit)</p> <p>Disconnect power supply for 15 seconds, then reconnect.</p> <p>Restart system. If problem persists, perform <b>OPTION 21 RE-INITIALIZE and 0-RECALIBRATE</b>. (pages 24-25)</p> <p>Reseat ribbon cables inside dome unit.</p>

SYMPTOM	POSSIBLE SOLUTION
<p>Only getting signal on 1/2 of transponders.</p>	<p>Verify coax cables are tightly crimped with <b>RADIAL (COMPRESSION)</b> style crimps only.</p> <p>Verify receiver is operating properly.</p> <p>Verify LNB type is set correctly.</p> <p>9762 / 9762-LP Dual and 9762-SW only: Verify De-stacker is installed. (P. 13)</p>
<p>Unit never locks on or locks on and drifts off of satellite.</p>	<p>Atmospheric moisture. Unit will lock on as weather improves.</p> <p>Check for obstruction in sky in direction of satellite. Select another satellite and verify unit locks on.</p> <p>Verify coax cables are tightly crimped with <b>RADIAL (COMPRESSION)</b> style crimps only.</p> <p>Perform <b>OPTION 21 RE-INITIALIZE and 0-RECALIBRATE</b>. (pages 24-25)</p> <p>Perform <b>Temperature Calibration</b>. (call King Controls)</p> <p>Inspect all coax cables and verify connections are snug but not overly tight. (inside and outside dome unit)</p>

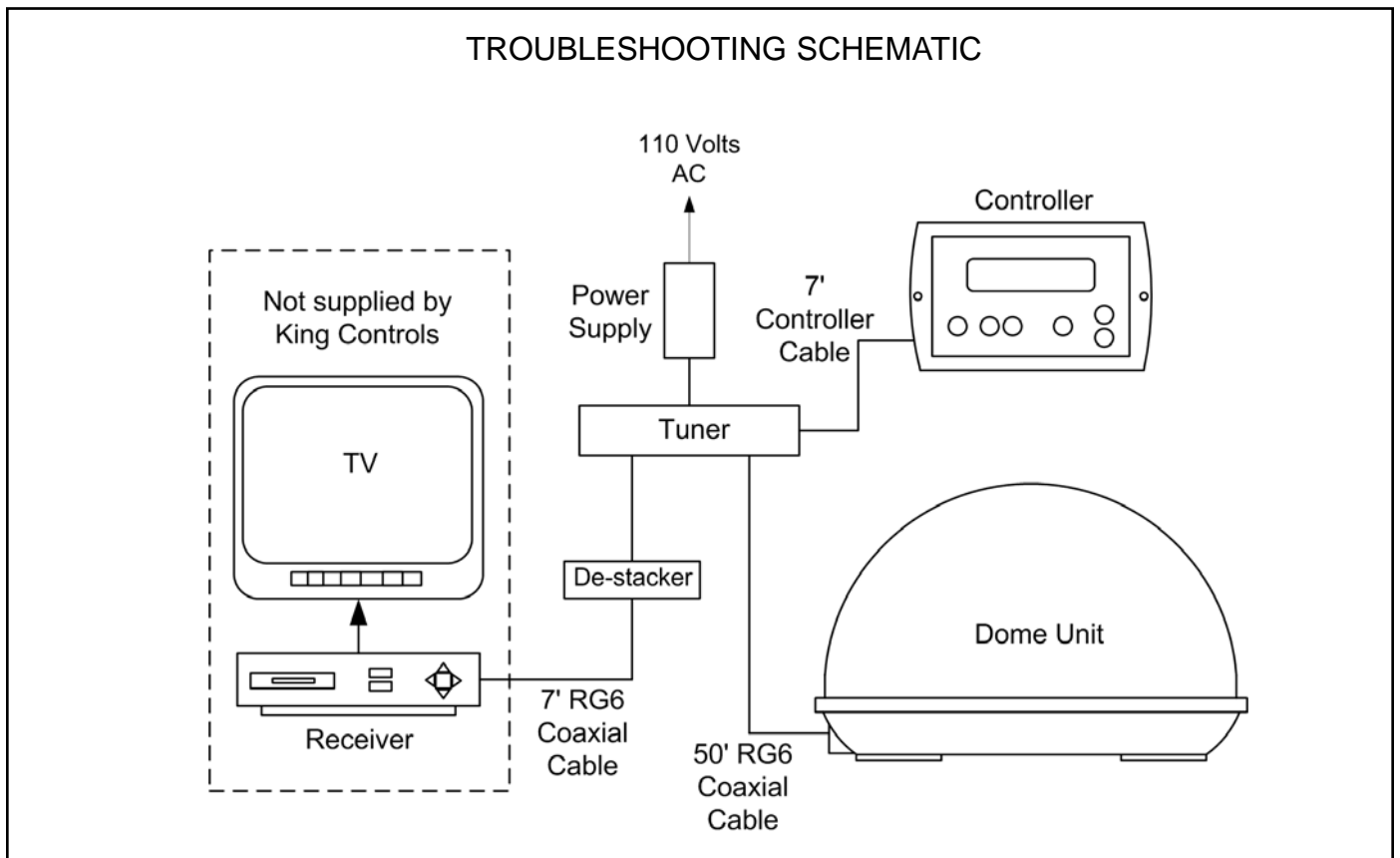

## OPTION 21 RE-INITIALIZE and 0-RECALIBRATE

1. Press **MAIN** button as needed to enter DEALER SETUP menu.



DEALER SETUP ==>  
CODE 0

2. Press **+** as needed to scroll up to CODE 13.

Press **ENTER**

DEALER SETUP ==>  
CODE 13

3. Press **→** as needed to enter SET OPTION menu.

SET OPTION  
OPTION 0

4. Press **-** as needed to scroll down to OPTION 21.

Press **ENTER** to re-initialize software.

SET OPTION  
OPTION 21

LOADING  
PLEASE WAIT

5. Wait until display shows OPTION 0.  
(May take up to 30 seconds.)

Press **ENTER** and **-** simultaneously to shut system off.

SET OPTION  
OPTION 0

off

6. Disconnect power (110 volt power supply) from tuner for 10 seconds, then reconnect.

**WAIT 10 SECONDS!**



7. Wait until controller shows "off" then press **ON** to start system.

off

8. Wait for system to load.

**POWER UP  
PLEASE WAIT**

**LOADING  
PLEASE WAIT**

When display shows RUN: SCAN ALIGN,  
press  to enter IDLE/HOLD mode.

**IDLE/HOLD**

9. Press  to enter USER SETUP menu.

**USER SETUP** ==>  
Rev xxxx sn xxxxx

10. Press  to enter SET REGION menu.

**SET REGION**

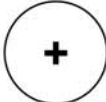
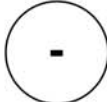
11. Press  or  as needed to display  
0-RECALIBRATE.

**SET REGION  
0-RECALIBRATE**

12. Press  to exit IDLE/HOLD mode.

**RUN: SCAN ALIGN**

13. Press  System recalibrates gyros.

**RUN: SCAN ALIGN  
0-RECALIBRATE**

(System will continue to run during recalibration process. Calibration is complete when 0-RECALIBRATE no longer scrolls across bottom of display with search information. May take up to 10 minutes.)

14. System continues to run after calibration is complete.

**RUN: SCAN ALIGN**

The Sea-King Satellite System has been designed to be maintenance and trouble free.

For optimum signal strength, keep the dome clean from dirt, bugs, and other debris. Periodic washing of the dome with mild soap and water is recommended.

If you plan on storing your vessel for long periods of time, it is recommended that the system be put through a search procedure on a quarterly basis to keep all moving parts in good working order.

If you have any comments or questions, please contact the King Controls Service Department at 1-800-982-9920, or email King Controls at [info@kingcontrols.com](mailto:info@kingcontrols.com)

Every King Controls Satellite System is thoroughly inspected and tested before leaving the factory. It is covered by a two year parts and one year labor limited warranty from the date of original purchase. This warranty does not cover installation and external wiring or refurbished units.

Should any trouble develop during the warranty period, contact King Controls or one of its certified dealers. Only King Controls and certified dealers are authorized to perform warranty evaluations and repairs.

If it is determined that the unit needs to be returned, return COMPLETE product, freight prepaid, to : **King Controls, 11200 Hampshire Ave. S, Bloomington, MN 55438-2453**. If inspection shows the trouble is caused by defective workmanship or material, King Controls will repair (or at its option, replace) without charge.

This warranty does not apply where:

- The product has been abused, misused, improperly installed or improperly maintained.
- Repairs have been made or attempted by others that are not certified by King Controls to do such repairs.
- Repairs are required because of normal wear and tear.
- Alterations have been made to the product

**In no event shall King Controls be liable for any indirect, incidental, or consequential damages from the sale or use of the product. This disclaimer applies both during and after the term of the warranty.**

**King Controls disclaims liability for any implied warranties, including implied warranties of “merchantability” and “fitness for a specific purpose,” after the one year term of this warranty.**

This warranty gives you specific legal rights, and you may also have other rights, which vary from state to state. Some states do not allow the exclusion or limitation of incidental or consequential damages, so the above limitation or exclusion may not apply to you. Some states do not allow limitations on how long an implied warranty lasts, so the above limitation may not apply to you.



11200 Hampshire Avenue South, Bloomington, MN 55438-2453  
Phone: 800-982-9920 Fax: 952-922-8424

[www.kingcontrols.com](http://www.kingcontrols.com)

