



Sea-King Fully Stabilized Marine Satellite System

9815-RJ 9818-RJ

Installation and Operating Instructions



MEMBER



Satellite Solutions for Mobile Markets

11200 Hampshire Avenue South, Bloomington, MN 55438-2453
Phone: (800) 982-9920 Fax: (952) 922-8424

www.kingcontrols.com

IMPORTANT!

The satellite TV market is expanding and changing. The information in this manual was accurate at the time of printing. If your Sea-King System does not operate as outlined in this manual please call King Controls at (800) 982-9920 or visit our website at www.kingcontrols.com.

TABLE OF CONTENTS

Section	Contents	Page
1.	INTRODUCTION.....	2
2.	DEFINITION OF TERMS	3
3.	INSTALLATION	4-17
4.	OPERATION	18-21
5.	TROUBLESHOOTING	22-26
6.	MAINTENANCE	27
7.	LIMITED WARRANTY	28

ELECTRICAL HAZARD WARNING!

The coaxial cable that connects the dome unit to the tuner carries a 24 volt electrical current. Exercise extreme caution when handling this cable. Do not cut, break, or splice this line. Do not insert or connect any devices such as splitters or any other device for any reason. This line is not compatible with any other equipment. Damage will occur to any device other than the dome unit if connected to the antenna port on the tuner.

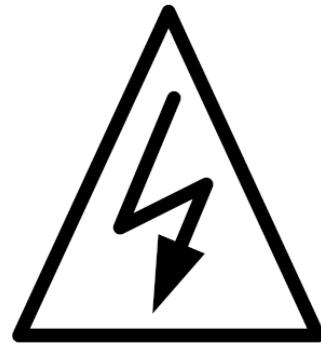

The Sea-King Fully Stabilized Marine Satellite System includes 4 main components (**Fig. 1**).

Dome (Antenna) Unit	Mounted on the vessel. The dish is covered by a protective dome that keeps operational components free from the elements.
Controller	Located in the vessel. Used to activate and monitor the system, and access programming and diagnostic information.
Tuner	Located in the vessel. Decodes the satellite signal so the Sea-King locks onto and tracks the correct satellite.
Power Supply	Located in the vessel. Supplies proper operating voltage to the Sea-King.

Note: A TV, satellite receiver, and program subscription are also required for satellite TV viewing. (Not supplied by King Controls.)

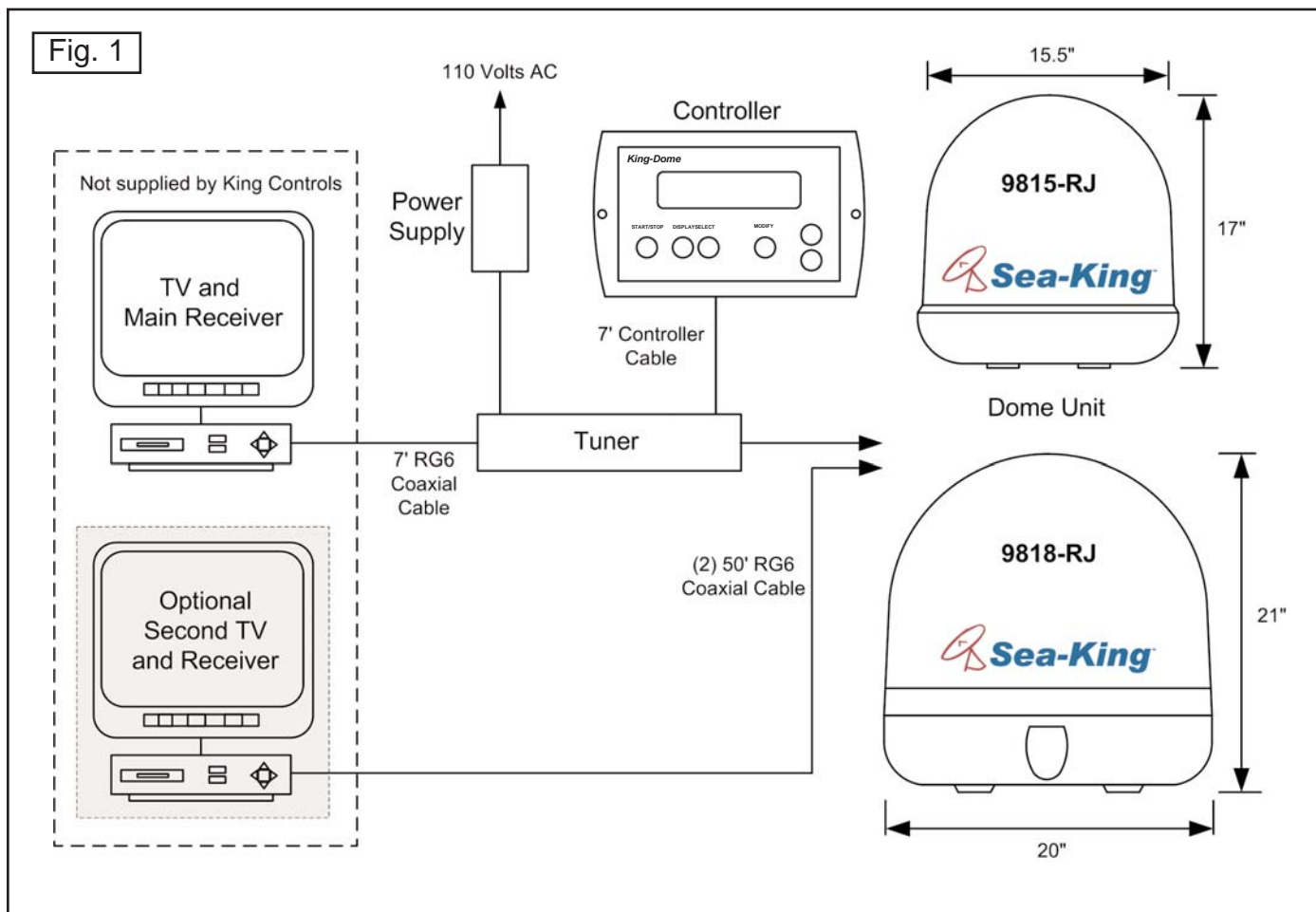

AZIMUTH: Angle in degrees measured clockwise from Magnetic North (0°) (Fig. 2).

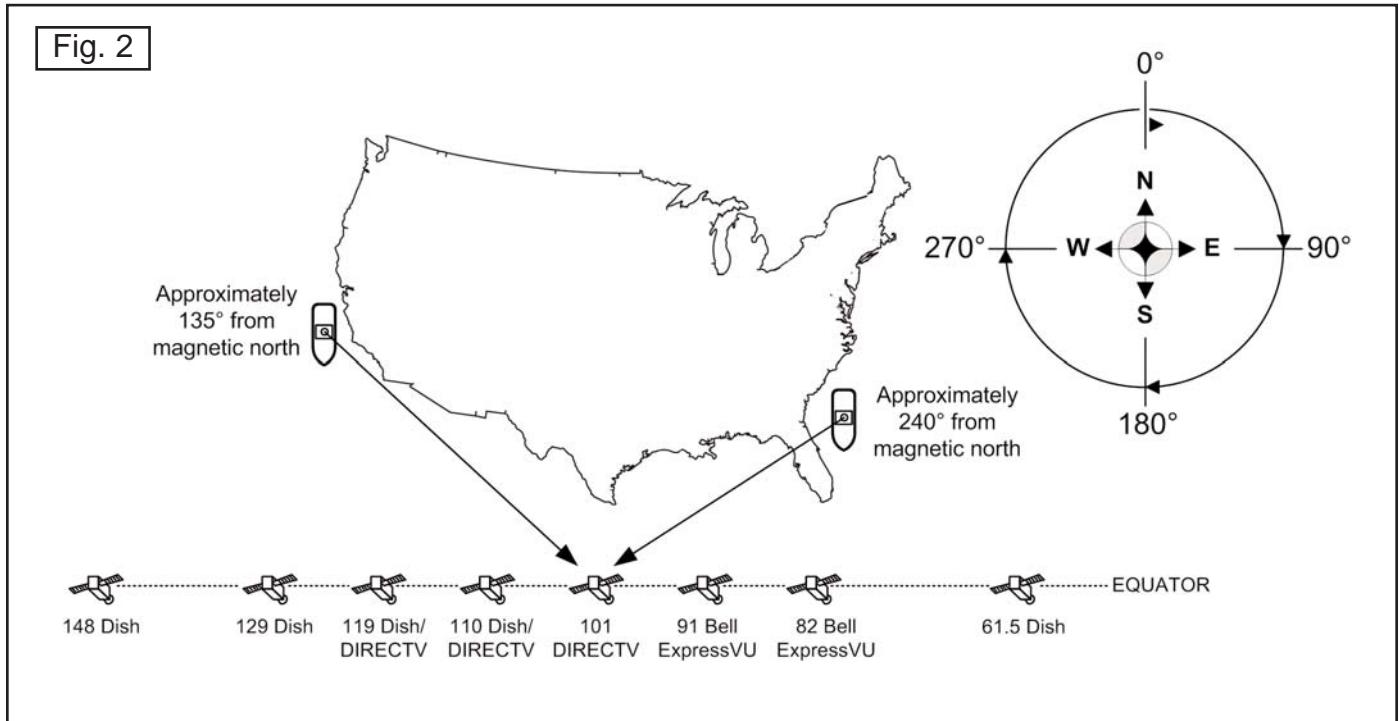

ELEVATION: Angle in degrees measured from the ground plane (Fig. 3).

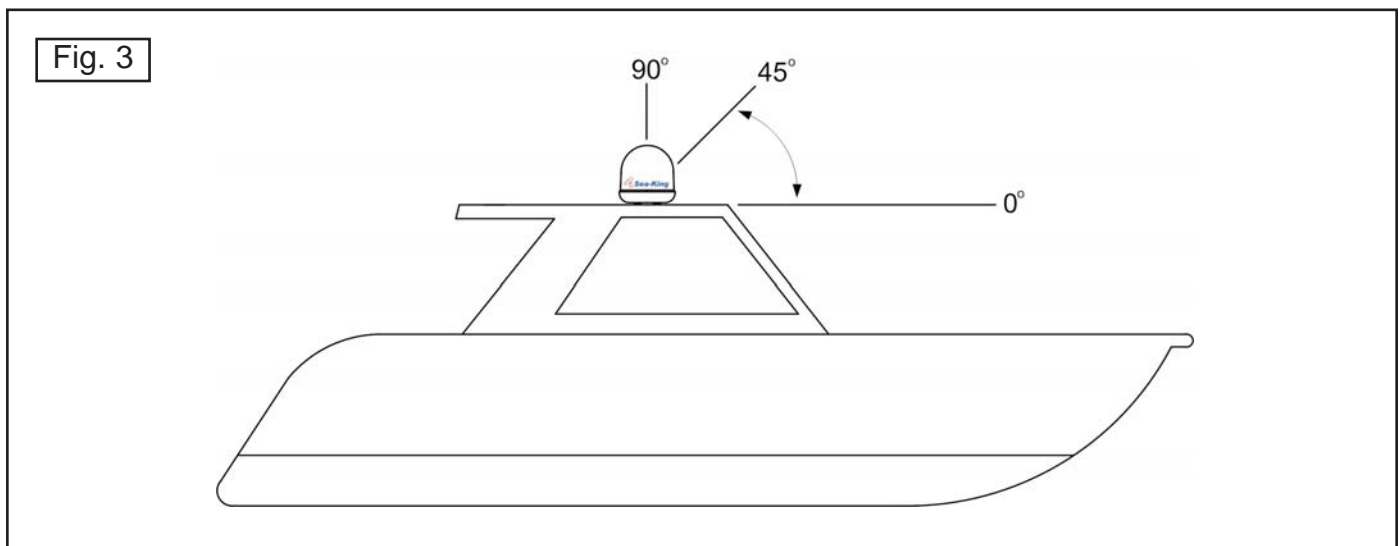

SIGNAL STRENGTH: Intensity of electronic signal received from the satellite transmission.

TOOLS AND MATERIALS REQUIRED:

- drill and drill bit set
- tape measure
- 7/16" open end wrench (coax connections)
- 5/32" allen wrench, channel lock or pliers (to remove shipping bolt)
- 1/8" allen wrench or phillips screw driver (to remove dome cover)
- appropriate fasteners and tools to install all components and wiring
- adhesive sealant, compatible with vessel material

KIT CONTENTS:

1. Unpack and identify all components (**Fig. 4**).

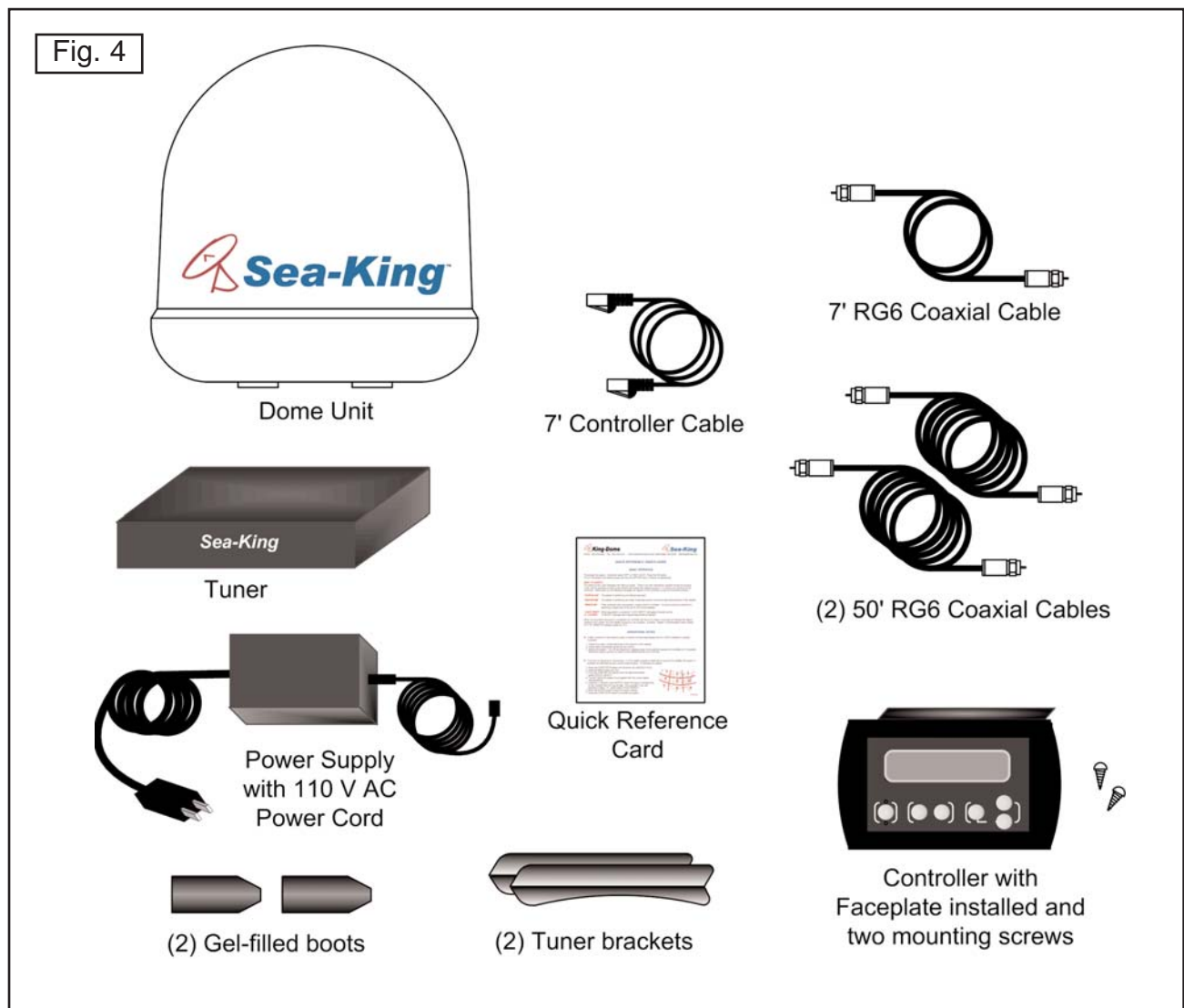

DOMES LOCATION

1. Select an area on the vessel for the dome unit, keeping in mind the coax cables will enter the vessel through the surface directly beneath the dome unit. Use the following criteria:
 - a) The shortest distance between the dome unit and the main satellite receiver is most desirable.
 - b) The dome unit requires either a 16.5 inch (9815-RJ) or 20 inch (9818-RJ) diameter mounting area on the vessel surface, or an industry standard mount (call King Controls for more information).
 - c) The dome should never be mounted so that it is tilted more than two degrees in any direction.
 - d) Keep the dome unit as far away from the radar as possible, and if possible above the level of the radar.
 - e) The dome unit should be mounted as close as possible to the center of the vessel (fore-aft and side to side).
 - f) The mounting surface must be strong enough not to flex under the weight of the unit or from vessel vibrations.
 - g) There must be no "line of sight" obstructions from this location. Items such as masts or radar antennas that are too close to the dome unit may prevent the satellite signal from reaching the dish (**Fig. 5**).

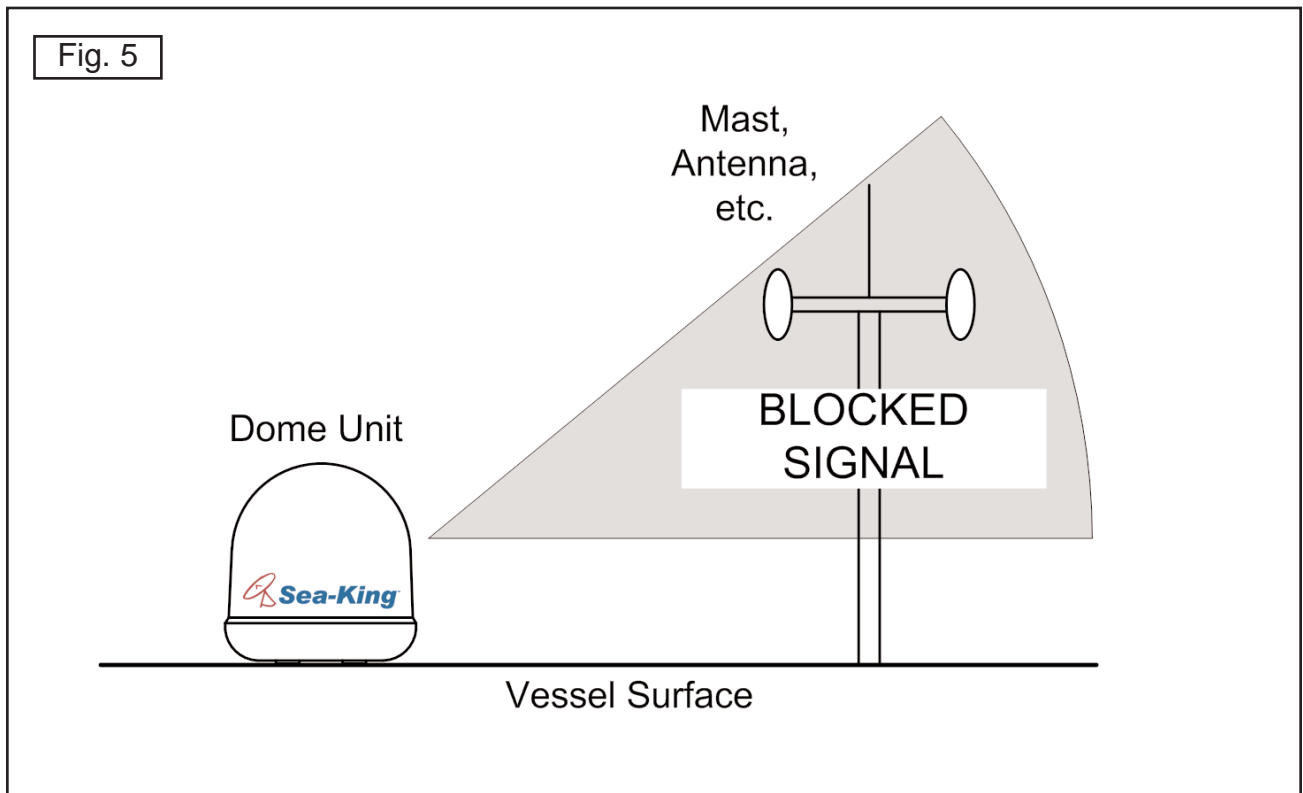
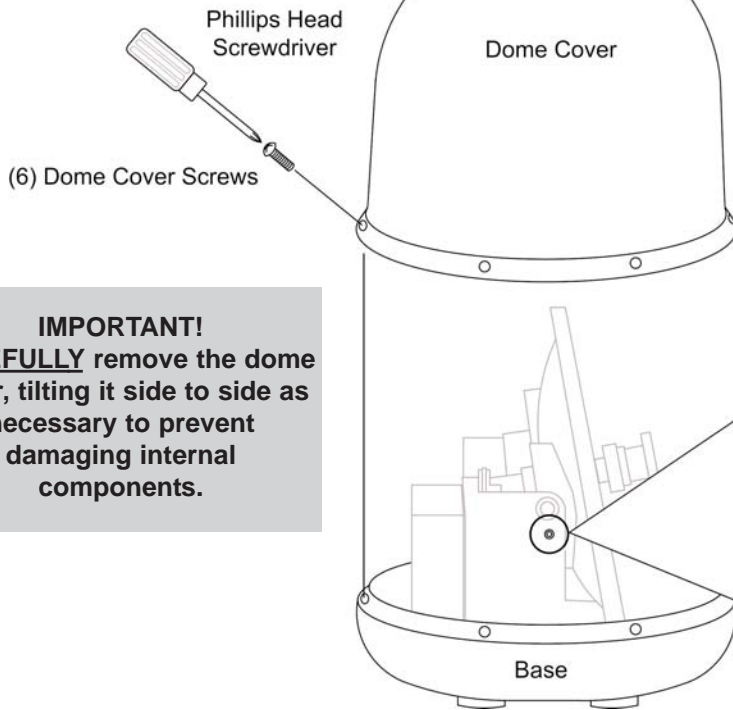

Fig. 6A

9815-RJ



IMPORTANT!
The shipping bolt must be removed prior to installation.

IMPORTANT!
CAREFULLY remove the dome cover, tilting it side to side as necessary to prevent damaging internal components.

Fig. 6B

9818-RJ

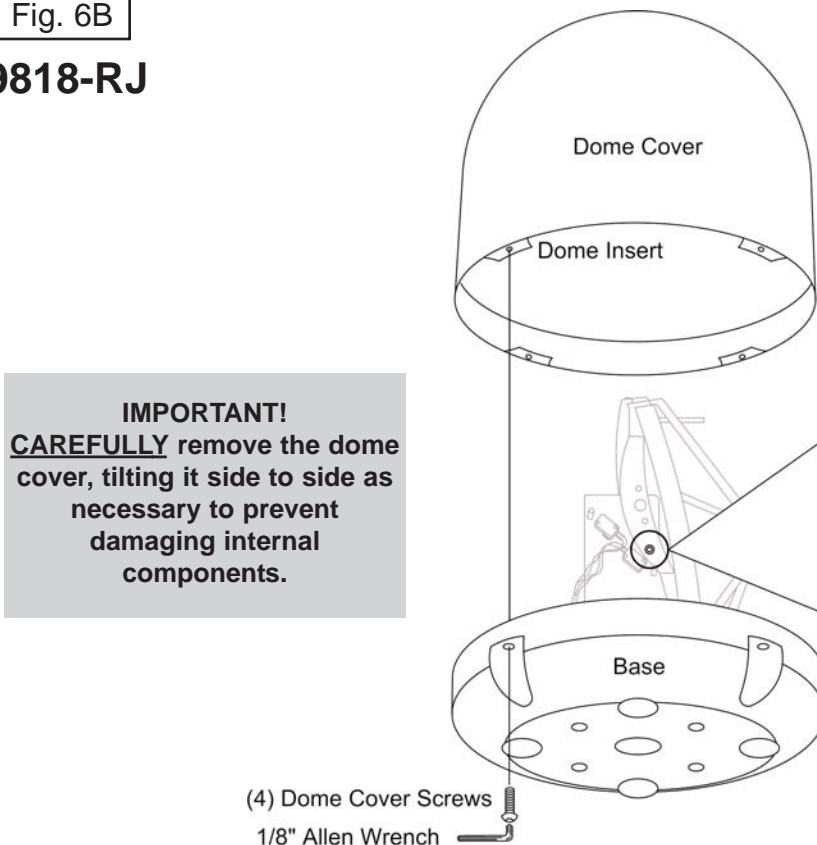

IMPORTANT!
The shipping bolt must be removed prior to installation.

IMPORTANT!
CAREFULLY remove the dome cover, tilting it side to side as necessary to prevent damaging internal components.

EXTREMELY IMPORTANT!

**NEVER lift the unit by the LNB assembly, Wave Guide assembly, or the dish.
Lift the unit ONLY by the base.**

4. Place the dome unit on its mounting pedestal and temporarily secure the unit from falling. **DO NOT PERMANENTLY MOUNT THE DOME UNIT UNTIL YOU HAVE COMPLETED THE SYSTEM LOCATION CHECK ON THIS PAGE.**

If mounting to the vessel surface, you will need to temporarily place it on a pedestal to perform the system location check.

ELECTRICAL HAZARD WARNING!

The coaxial cable that connects the dome unit to the tuner carries a 24 volt electrical current. Exercise extreme caution when handling this cable. Do not cut, break, or splice this line. Do not insert or connect any devices such as splitters or any other device for any reason. This line is not compatible with any other equipment. Damage will occur to any device other than the dome unit if connected to the antenna port on the tuner.

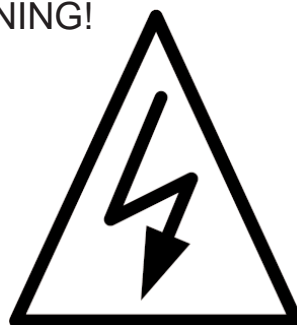

AVOID SHARP BENDS WHEN ROUTING COAX!

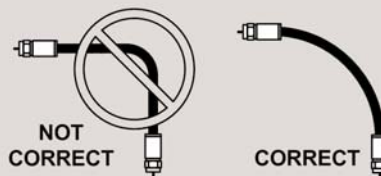

To verify proper operation of the components in their selected locations, perform a System Location check as follows:

5. Connect system as outlined in **Fig. 10, Page 13**.
6. Verify system operates properly as described in **Section 4 OPERATION, Page 18**.
7. After verifying proper operation of the system, disconnect all components.

DOMESTIC INSTALLATION AND EXTERNAL WIRING

IMPORTANT! USE ONLY THE COAXIAL CABLES SUPPLIED WITH THE SEA-KING. DO NOT CUT COAX. COIL AND STORE EXCESS CABLE IN THE CABINET WITH THE COMPONENTS.

If coaxial cable other than that supplied with the Sea-King is used, the following guide lines must be followed:

- 1) Ends must be terminated with SNAP-N-SEAL® connectors or F-compression style connectors as shown in Fig. 7. **(DO NOT USE TWIST-ON CONNECTORS.)**
- 2) Cable must be RG6 or better, and rated at 2.2 GHz or higher.

Fig. 7

IMPORTANT!
Use factory recommended stripper only.



Fold wire braiding back.

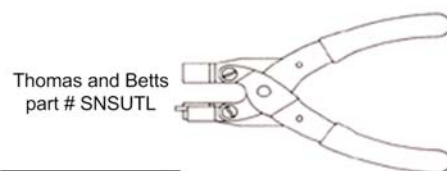
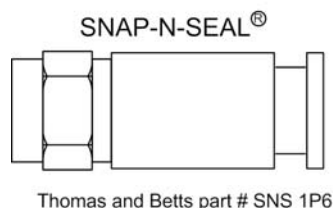
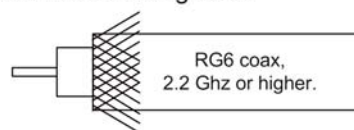

IMPORTANT!
Rubber O-rings must be **REMOVED** from ends of all SNAP-N-SEAL® connectors and F-compression style connectors.

IMPORTANT!
COMPRESSION STYLE CRIMPER ONLY!
(Do not use hex style.)

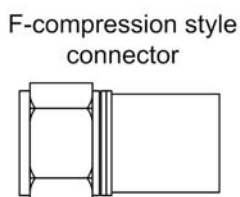

1/16" Min. to 1/8" Max.

STINGER

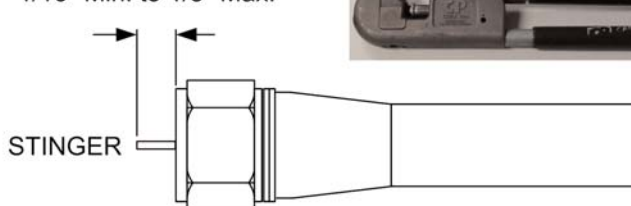

IMPORTANT! The installer is responsible for weatherproofing all holes in the vessel.

Note: The installer is responsible for determining the most appropriate fastener to secure the dome unit to the pedestal or vessel surface. Depending on the surface material, fasteners such as lag screws, well nuts, sheet metal screws, toggle bolts and T anchors may be used.

Use the included white foam gasket(s) to seal the coax connection area (see **Fig. 8** for mounting configurations).

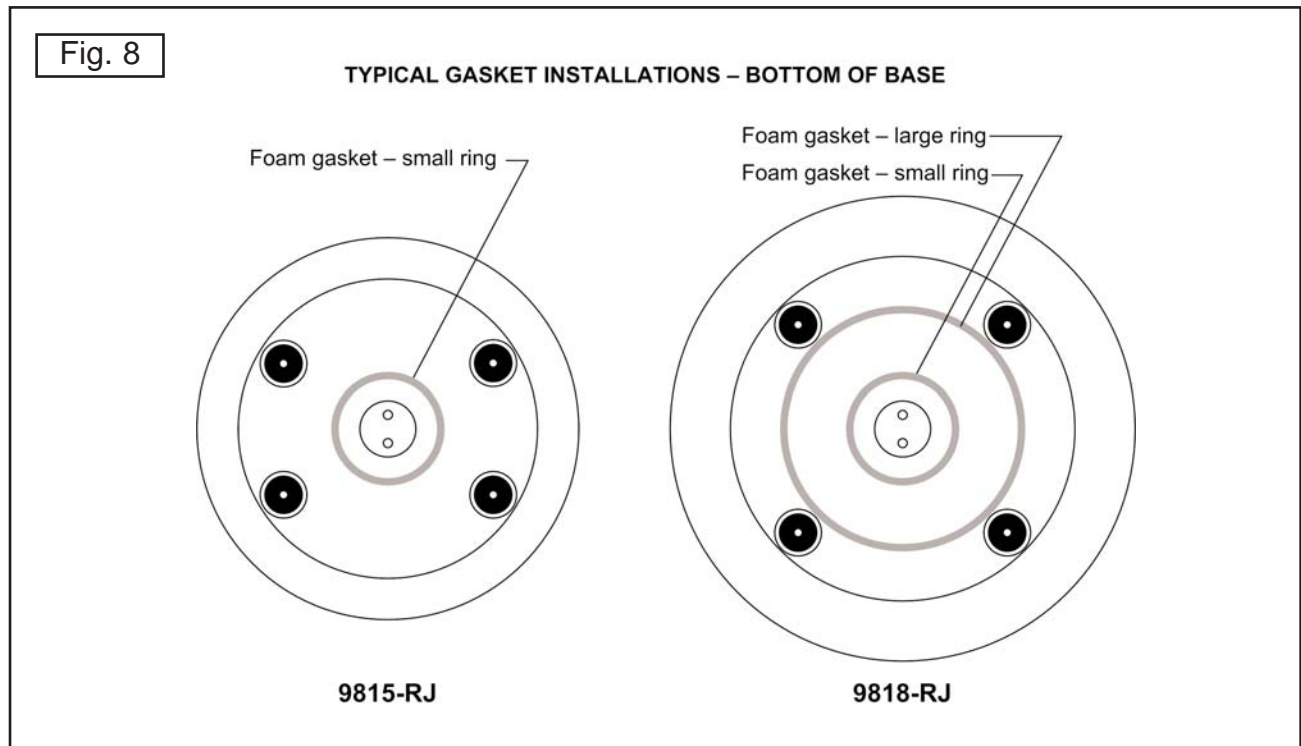

IMPORTANT! Make sure power supply is disconnected from 110 volt source before continuing with permanent installation.

1. Mount the dome unit. Use the four mounting holes inside the base to install the dome unit to the pedestal or the vessel surface.

Note: The King-Dome is wired for a dual LNB. There are two coaxial ports on the bottom of the dome unit. The one labeled “MAIN” must be connected to the Tuner (IDB) in vessel. The unlabeled port can be used for an additional receiver (see page 13). If using both coax, label the other end of one to avoid confusion when making the internal hookups.

Apply non-conductive electrolytic grease to all stingers (coax cable center conductors) before installation.

2. Connect 50' coax cable to the coax port labeled MAIN on the bottom of the dome unit and tighten connection. If using a second receiver, connect second 50' coax cable to the unlabeled port and tighten connection. **DO NOT OVER TIGHTEN CONNECTIONS (Fig. 9).**
3. Snap the gel-filled boots around the coax cables, then push flush against the rubber sleeves on the coax ports (**Fig. 9**).

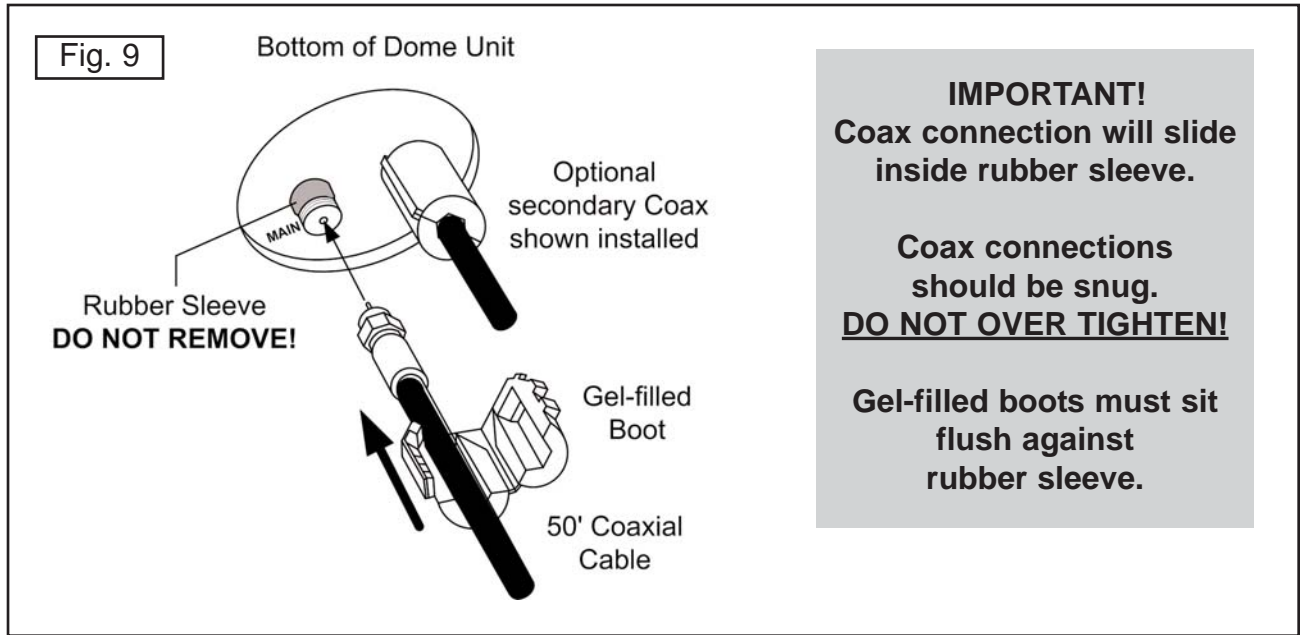

AVOID SHARP BENDS WHEN ROUTING COAX!

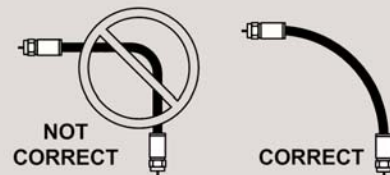

4. Run coax cable(s) from the dome unit to the location where they will enter the vessel. Secure coax every 12-18 inches.
5. Drill 3/4" hole in the vessel where the tuner will be located. Feed coax cable(s) down through hole. Seal opening so that it is entirely waterproof (inside and outside of the 3/4" hole).

IMPORTANT! When re-installing the dome cover, **CAREFULLY** lower it onto the base, tilting it side to side as necessary to prevent damaging internal components.

6. Replace dome cover on base and align holes in dome cover with holes in base. Attach dome cover with dome cover screws saved earlier. Tighten **ALL** screws securely.

ELECTRICAL HAZARD WARNING!

The coaxial cable that connects the dome unit to the tuner carries a 24 volt electrical current. Exercise extreme caution when handling this cable. Do not cut, break, or splice this line. Do not insert or connect any devices such as splitters or any other device for any reason. This line is not compatible with any other equipment. Damage will occur to any device other than the dome unit if connected to the antenna port on the tuner.

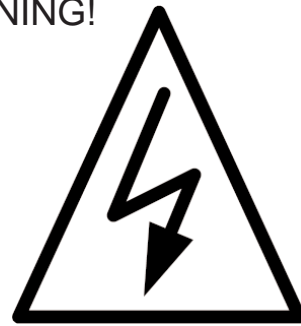

INTERNAL WIRING (Fig. 10)

IMPORTANT! The 50' coax from the "MAIN" port on the dome unit MUST be connected to the Tuner (IDB) in the vessel.

Coax connections should be snug. DO NOT OVER TIGHTEN!

Note. Apply non-conductive electrolytic grease to all stingers before installation.

1. Connect the 50' coax cable from "MAIN" on dome unit to the tuner port labeled "ANT."
2. Connect the 7' coax from the tuner port labeled "REC" to the main satellite receiver port labeled "SATELLITE IN."
3. Connect the 7' controller cable from the controller to the tuner port labeled "IDD."
4. If installing a second receiver, connect the 50' coax cable from "AUX" on dome unit to the "SATELLITE IN" port on the second receiver.

Note: Make sure the proper connections are made between the receivers and TVs.

IMPORTANT! When connecting the power supply cable to the tuner, push in the power supply cable end until it is flush against the back of the tuner.

5. Connect the power supply cable to the tuner port labeled "PWR".
6. Plug the power supply into a 110 VAC source.

Note: The controller should turn on for 3 seconds and then turn off. If the controller stays on, press the ENTER and "-" button simultaneously for 3 seconds to turn unit off.

Fig. 10

9815-RJ 9818-RJ WIRING DIAGRAM

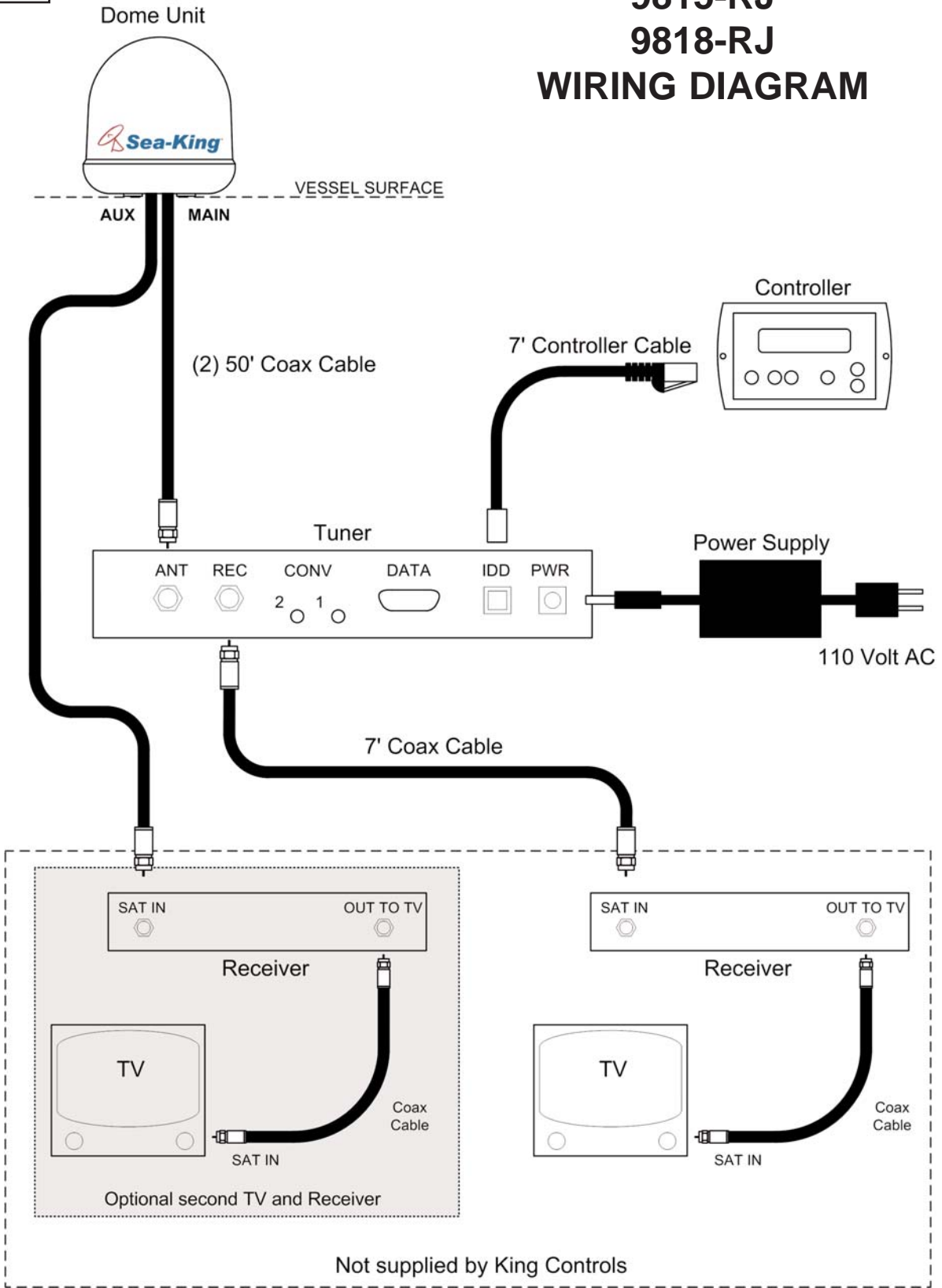

IMPORTANT! AVOID SHARP BENDS WHEN ROUTING COAX.

MULTIPLE SATELLITE RECEIVER CONFIGURATIONS

With the use of an active multi-switch (not supplied by King Controls), more than two TV's and receivers can be hooked up (see **Fig. 11** for typical 4 receiver hookup).

Other options:

3-4 satellite receivers: use one 2x4 or 3x4 active multi-switch

8 satellite receivers: use one 2x8 or 3x8 active multi-switch

16 satellite receivers: use one 3x16 active multi-switch

King Controls recommends the use of an active multi-switch.
Recommended brands (other brands may work as well):

Channel Master
Eagle Aspen
Perfect Vision
Spaun
Terk

Fig. 11

TYPICAL 4 RECEIVER HOOKUP

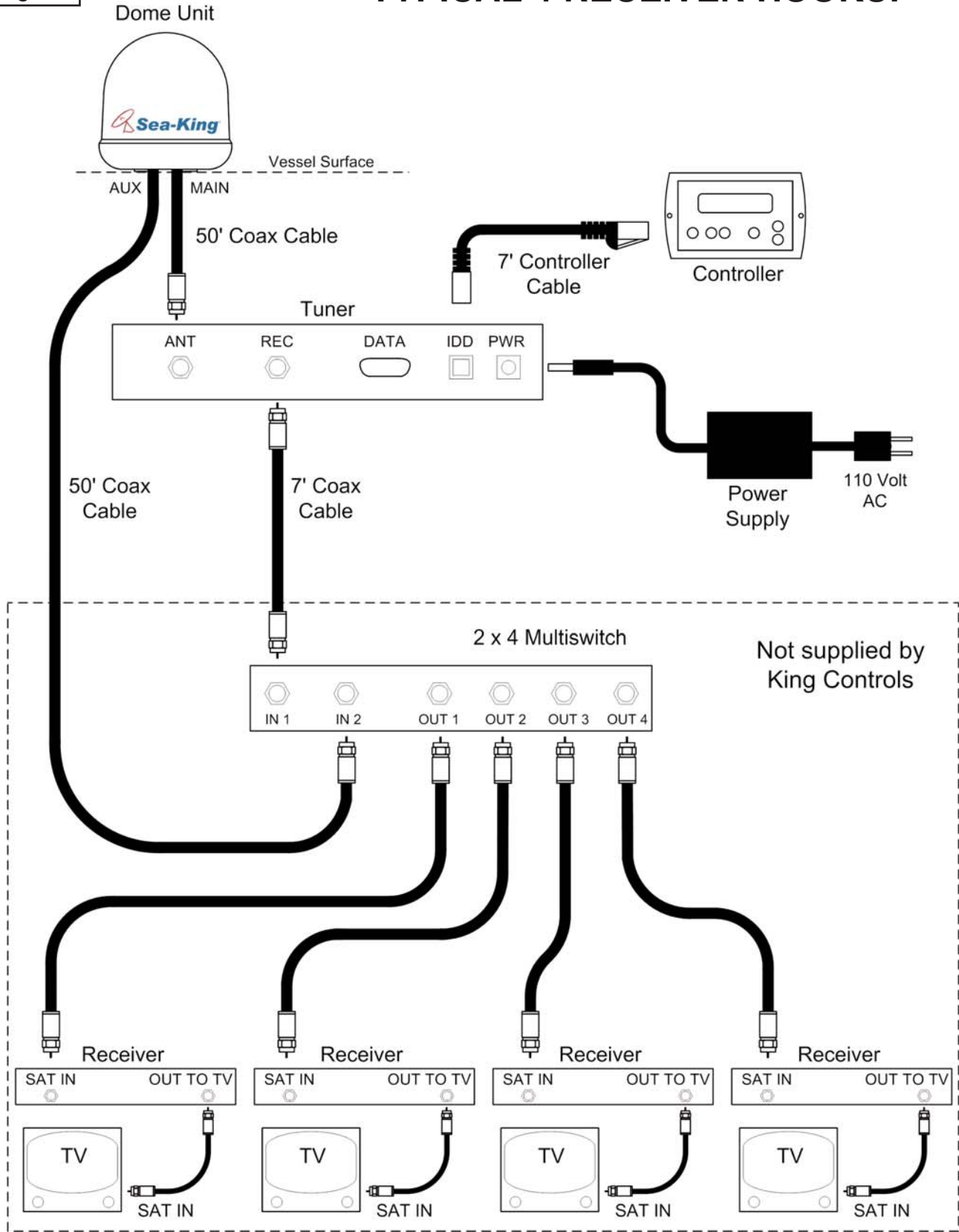

IMPORTANT! AVOID SHARP BENDS WHEN ROUTING COAX.

OPTIONAL WALL MOUNT FACEPLATE (INCLUDED)

Note: If not using the faceplate, see faceplate removal instructions below.

IMPORTANT! Depending on the thickness of the vessel wall, a relief notch may need to be cut for the cable. **THE CABLE MUST NOT BE PINCHED OR BENT WHEN MOUNTING THE DISPLAY.**

1. Use the Faceplate as a template to mark and cut out the mounting cavity, and if necessary, mark and drill the mounting holes (**Fig. 12**).
2. Mount Faceplate in wall with supplied screws.

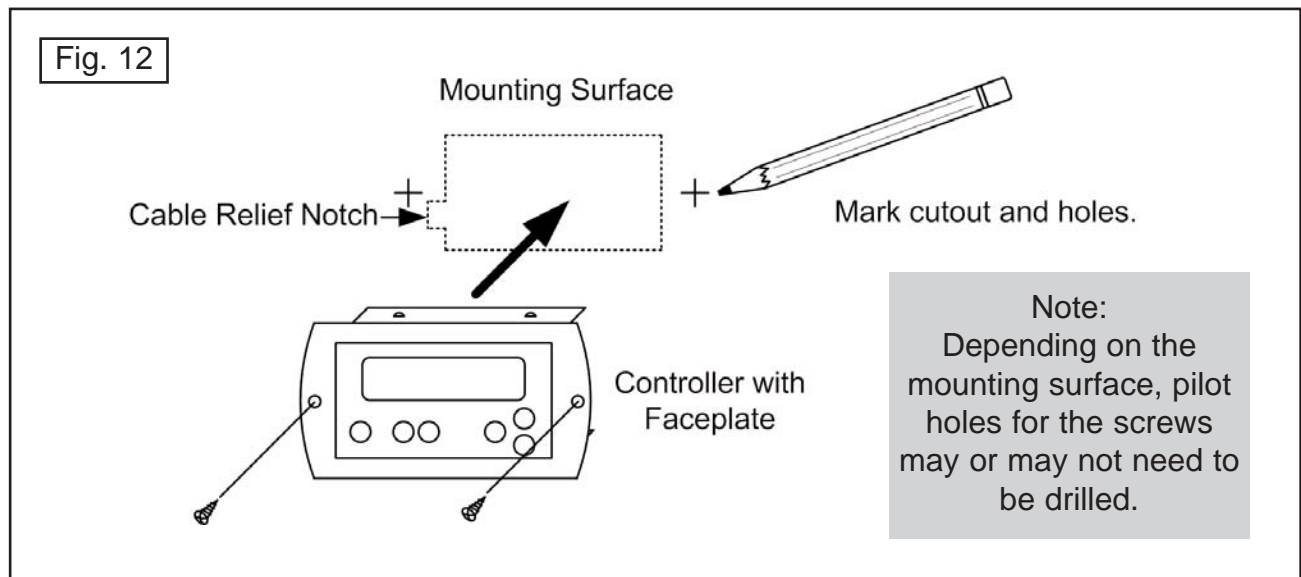

The Faceplate is optional and can be removed as follows: (**Fig. 13**)

1. Remove 4 screws from Controller.
2. Slide Faceplate off of Controller.
3. Replace 4 screws.

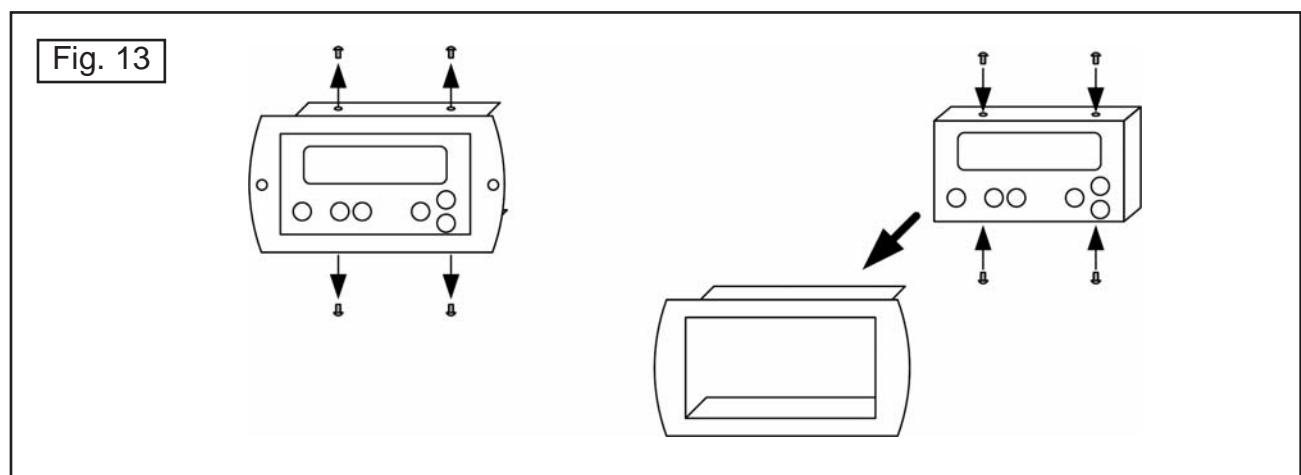

OPTIONAL TUNER MOUNTING BRACKETS (INCLUDED)

1. Remove 4 screws from the tuner.
2. Fasten mounting brackets to tuner with same screws (**Fig. 14**).

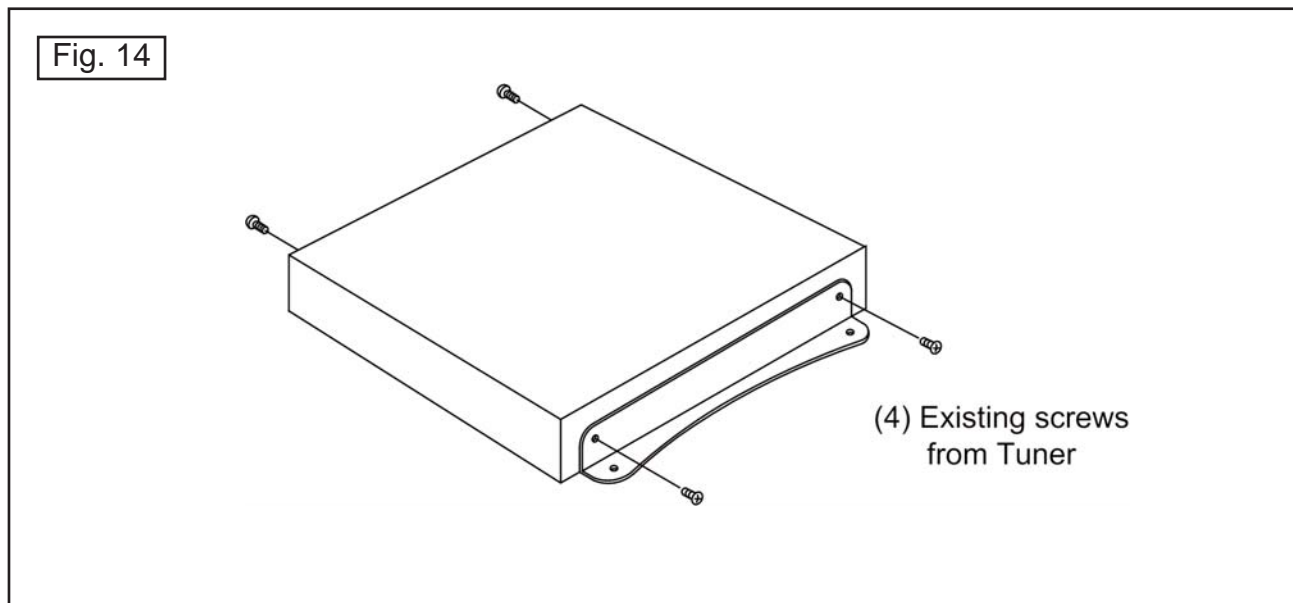

Note: The installer is responsible for determining the most appropriate fasteners to secure the mounting brackets to the chosen surface.

3. Mount tuner in previously chosen location (**Fig 15**).

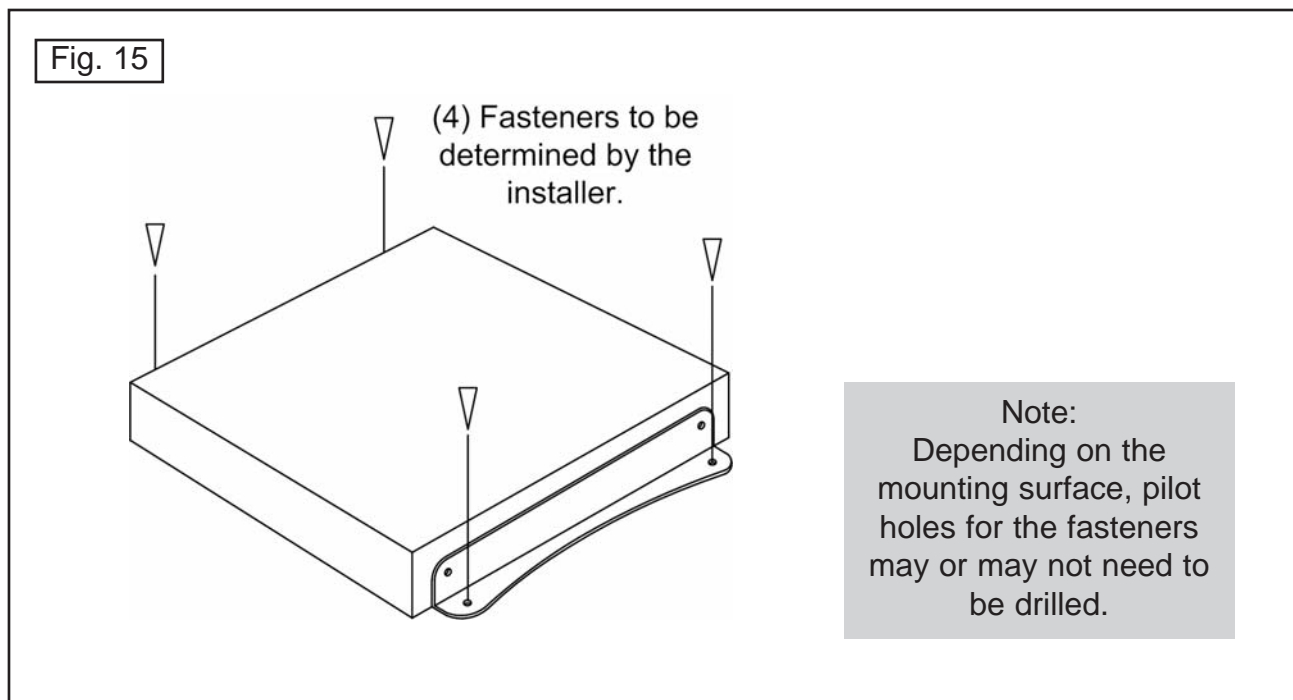

SECTION 4 OPERATION

IMPORTANT! There must be a clear “line of sight” to the satellite (See Fig. 2, Page 3). Terrain, other boats, buildings, trees, masts, telephone poles, etc. can all block the satellite signal from reaching the dish.

Note: This example is for the DTV 101 satellite in Region 2-North Central. The information on your controller will vary depending on the satellite and region you have chosen.

1. Turn on TV and satellite receiver. “Searching for Satellite Signal” or similar should appear on TV.

2. Press  ON

Unit powers up, performs a self-diagnostic and loads software.



**POWER UP
PLEASE WAIT**

IDB2 VER 1.x

Unit begins searching for the selected satellite.

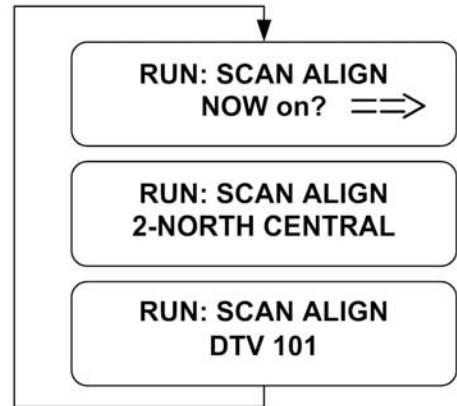



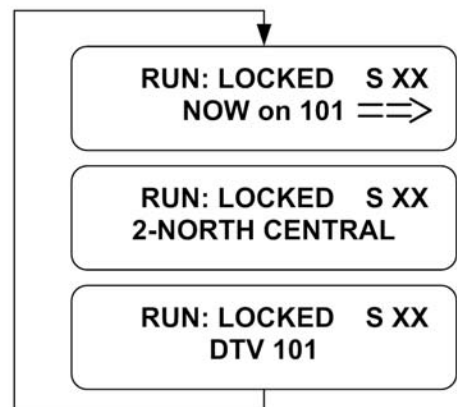









Unit has locked onto the selected satellite.

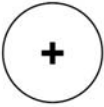

Note: The Sea-King must remain powered on to maintain a signal. If you are going to be stationary and wish to continue watching TV, **DO NOT TURN THE SYSTEM OFF.**

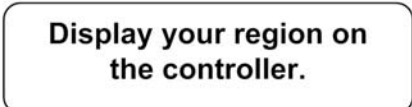
Note: To reduce satellite acquisition time, you can set your current region.

SET REGION (OPTIONAL)

1. Press  Unit goes into IDLE/HOLD mode. 
2. Press  Unit goes into USER SETUP menu. 
3. Press  Unit goes into SET REGION menu. 
4. Press  or  Find your location on the map below and determine which region you are in. Use the plus and minus buttons to display your region on the controller. 
5. Press  Sets REGION into memory. 
6. Press  Unit searches based on new REGION. 

REGION OPTIONS:

- 1 NORTH WEST
- 2 NORTH CENTRAL
- 3 NORTH EAST
- 4 CENTRAL WEST
- 5 MIDDLE CENTRAL
- 6 CENTRAL EAST
- 7 SOUTH WEST
- 8 SOUTH CENTRAL
- 9 SOUTH EAST
- 0 ALL REGIONS
- 0 RECALIBRATE

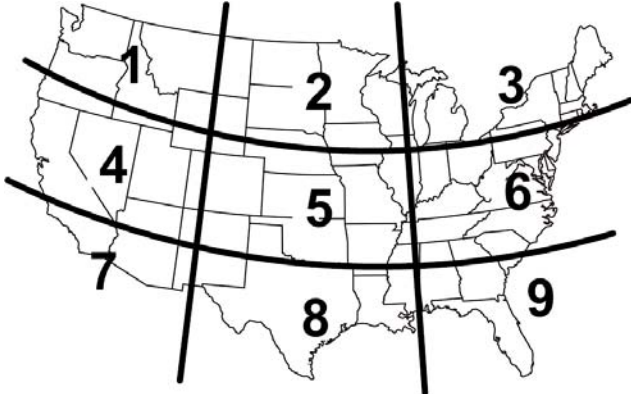

SET SATELLITE SERVICE

SATELLITE OPTIONS

DISH 61	Dish Network at 61
EXPVU 91	Bell ExpressVu at 91
DISH 129	Dish Network at 129
DISH 148	Dish Network at 148
EXPVU 82	Bell ExpressVu at 82
DTV 101	DIRECTV at 101
Sat 110	Dish Network at 110
Sat 119	Dish Network at 119
DTV 101/ 110 hd	DIRECTV at 101 and 110
DTV 101/ 119	DIRECTV at 101 and 119

Note: The King Controls HD TV Converter Box (#9747 or #9747-AM) is required to receive HD programming from the DIRECTV satellite at 110.

1. Press



Unit goes into SET SATELLITE menu.

SET SATELLITE

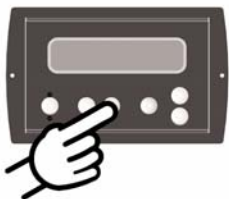

2. Press

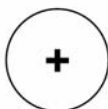

Use the plus and minus buttons to display your selected satellite on the controller.

**Display selected
satellite on controller.**

or

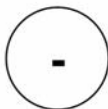

3. Press



Sets satellite in memory.
Unit moves to new selected satellite.

RUN: SWITCHING

RUN: LOCKED
Displays selected satellite

Note: **For DIRECTV Subscribers:** The satellite setting allows the user to select the satellite and service provider of choice. For DIRECTV subscribers, the Sea-King can also track a secondary or alternate satellite.

Example: If you are a subscriber to the DIRECTV service most of the programming that you will be watching will be transmitted from the satellite located at 101 degrees. You may also subscribe to programming that is transmitted from another satellite located at 119 degrees. In order to receive programming from both satellites you can either select an individual (DTV 101) satellite manually from the display or you can select a multiple (DTV 101/119) satellite setup. The multiple satellite selection will automatically switch between satellites (DTV 101/119) based on the channel or programming that you select on the Satellite Receiver (multi-satellite capable receiver is required). Please keep in mind that the programming may pause (freeze frame) or pixelate while the antenna acquires and locks onto the new satellite.

The multiple satellite setting will work only if your satellite receiver is set up to work in oval dish mode. Consult your satellite receiver manual for instructions.

It is not recommended to use the DTV 101/119 setting unless there is programming on the DTV 119 satellite that you specifically subscribe to.

For DISH NETWORK Subscribers: Use the procedure on the previous page to switch between the 110 and 119 satellites.

SYMPTOM	POSSIBLE SOLUTION
Controller does not power up.	Check: tuner is connected to power supply. controller is connected to tuner. power supply is plugged into 110 VAC outlet.
Controller remains in one of the following conditions: POWER TRIP ANT COM ERROR? TUNER COM ERROR?	Unplug tuner for 10 seconds, then plug back in. Check coax cables and connections between tuner and dome unit. Verify voltage on coax at dome unit is 24 volts.
Controller displays AZ FAULT. Dish cannot rotate.	Make sure shipping bolt is removed (see Page 7). Disconnect power supply for 15 seconds, then reconnect. Perform Mechanical Calibration (page 26). Perform OPTION 21 RE-INITIALIZE and 0-RECALIBRATE (pages 24-25). Reseat ribbon cables (inside dome unit).
Display reads EL FAULT.	Make sure shipping bolt is removed (see page 7). Disconnect power supply for 15 seconds, then reconnect. Perform Mechanical Calibration (page 26). Restart system. If problem persists, perform OPTION 21 RE-INITIALIZE and 0-RECALIBRATE (pages 24-25). Reseat ribbon cables inside dome unit.

SYMPTOM	POSSIBLE SOLUTION
<p>Only getting signal on 1/2 of transponders.</p>	<p>Kinked or sharply bent coax cable.</p> <p>Verify coax cables are tightly crimped with F-compression style crimps only.</p> <p>Verify receiver is operating properly.</p> <p>Verify LNB type is set correctly.</p>
<p>Unit never locks on or locks on and drifts off of satellite.</p>	<p>Atmospheric moisture. Unit will lock on as weather improves.</p> <p>Check for obstruction in sky in direction of satellite. Select another satellite and verify unit locks on.</p> <p>Verify coax cables are tightly crimped with F-compression style crimps only.</p> <p>Perform OPTION 21 RE-INITIALIZE and 0-RECALIBRATE (pages 24-25).</p> <p>Perform Temperature Calibration. Call King Controls (800) 982-9920.</p> <p>Inspect all coax cables and verify connections are snug but not overly tight (inside and outside dome unit).</p>

OPTION 21 RE-INITIALIZE and 0-RECALIBRATE

1. Press **MAIN** as needed to enter DEALER SETUP menu.



DEALER SETUP ==>>
CODE 0

2. Press **+** as needed to scroll up to CODE 13.

Press **ENTER**

DEALER SETUP ==>>
CODE 13

3. Press **→** as needed to enter SET OPTION menu.

SET OPTION
OPTION 0

4. Press **-** as needed to scroll down to OPTION 21.

Press **ENTER** to re-initialize software.

SET OPTION
OPTION 21

LOADING
PLEASE WAIT

5. Wait until display shows OPTION 0.
(May take up to 30 seconds.)

Press **ENTER** and **-** simultaneously to shut system off.

SET OPTION
OPTION 0

off

6. Disconnect power (110 volt power supply) from tuner for 10 seconds, then reconnect.

WAIT 10 SECONDS!

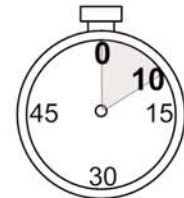

7. Wait until controller shows "off" then press **ON** to start system.

off

8. Wait for system to load.

**POWER UP
PLEASE WAIT**

**LOADING
PLEASE WAIT**

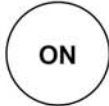
When display shows RUN: SCAN ALIGN,
press  to enter IDLE/HOLD mode.

**IDLE/HOLD SXX
NOW on ? ==>**

9. Press  to enter USER SETUP menu.

**USER SETUP ==>
Rev xxxx sn xxxxx**

10. Press  to enter SET REGION menu.

**SET REGION
■■■■■■■■**

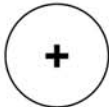
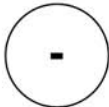
11. Press  or  as needed to display
0-RECALIBRATE.

**SET REGION
0-RECALIBRATE**

12. Press  System recalibrates gyros.

**RUN: SCAN ALIGN
0-RECALIBRATE**

13. Press  to exit IDLE/HOLD mode.

RUN: SCAN ALIGN

System will continue to run during recalibration process. Recalibration is complete when 0-RECALIBRATE no longer scrolls across bottom of display with search information. May take up to 10 minutes.

14. System continues to run after recalibration is complete.

**RUN: SCAN ALIGN
DTV 101**

MECHANICAL CALIBRATION

IMPORTANT! You must call King Controls before performing this procedure.

IMPORTANT! The Sea-King must remain perfectly still during the mechanical calibration.

The Sea-King must be running (NOT IN IDLE/HOLD).

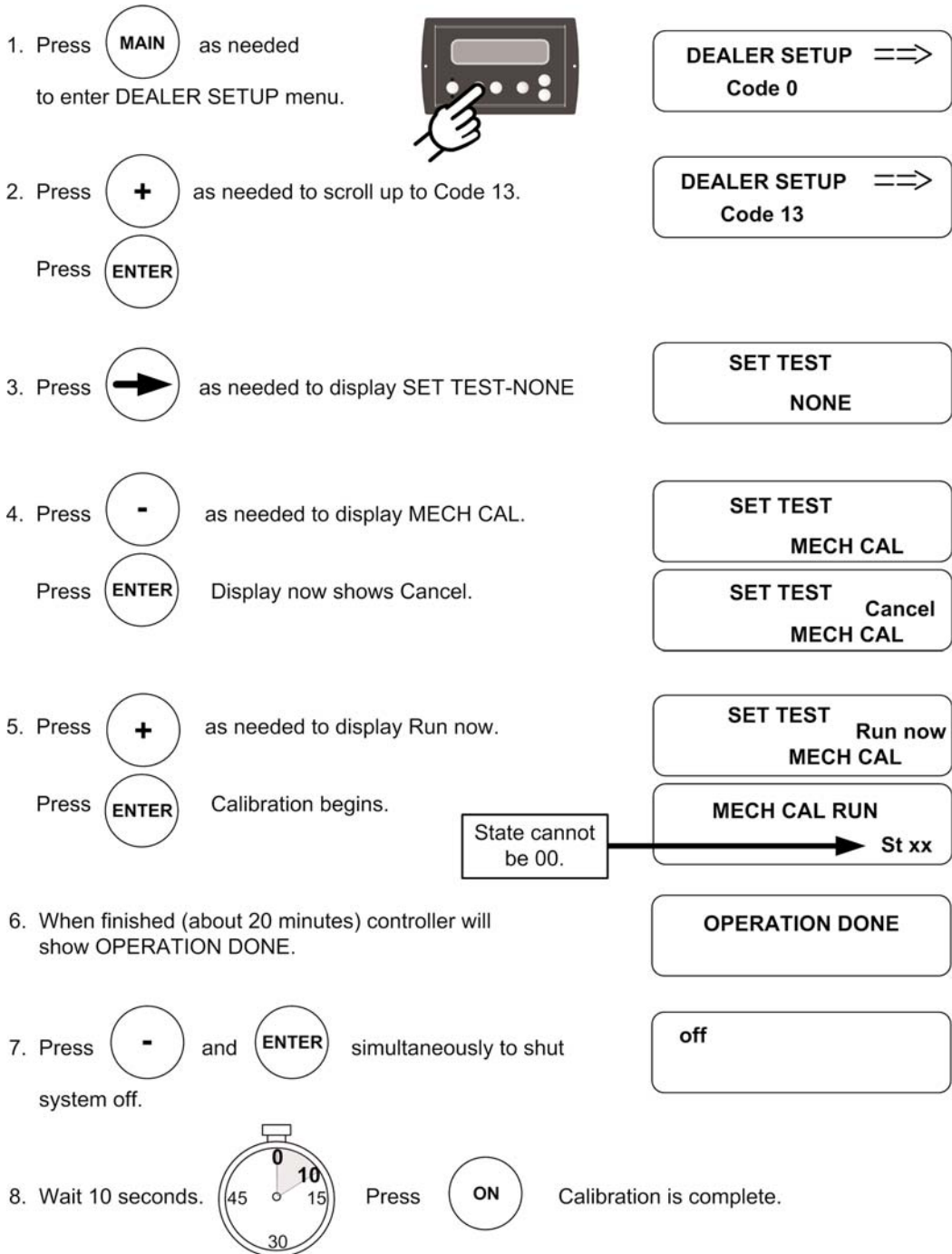

The Sea-King Satellite System has been designed to be maintenance and trouble free.

For optimum signal strength, keep the dome clean from dirt, bugs, and other debris. Periodic washing of the dome with mild soap and water is recommended.

If you plan on storing your vessel for long periods of time, it is recommended that the system be put through a search procedure on a quarterly basis to keep all moving parts in good working order.

If you have any comments or questions, please contact the King Controls Service Department at (800) 982-9920, or email King Controls at info@kingcontrols.com

Rain Fade

Rain or dew on the dome can cause signal interference and make the digital picture freeze, pixel or go out altogether. This loss of signal is commonly referred to as “rain fade” and is caused by the combination of water in the atmosphere and water on the dome surface.

To minimize this issue and eliminate the effects of water on the dome, apply King Controls’ **Dome Magic**[®] rain fade solution to the dome. This will prevent water from sticking to the dome surface and blocking the signal. For additional details on **Dome Magic**[®] rain fade solution please contact your authorized King-Dome dealer or call King Controls at (800) 982-9920.



Single Application Packet #1830-SP



Spray Can #1830

Every King Controls Satellite System is thoroughly inspected and tested before leaving the factory. It is covered by a two year parts and one year labor limited warranty from the date of original purchase. This warranty does not cover installation and external wiring or refurbished units.

Should any trouble develop during the warranty period, contact King Controls or one of its certified dealers. Only King Controls and certified dealers are authorized to perform warranty evaluations and repairs.

If it is determined that the unit needs to be returned, return COMPLETE product, freight prepaid, to :
King Controls, 11200 Hampshire Ave. S, Bloomington, MN 55438-2453. If inspection shows the trouble is caused by defective workmanship or material, King Controls will repair (or at its option, replace) without charge.

This warranty does not apply where:

- The product has been abused, misused, improperly installed or improperly maintained.
- Repairs have been made or attempted by others that are not certified by King Controls to do such repairs.
- Repairs are required because of normal wear and tear.
- Alterations have been made to the product

In no event shall King Controls be liable for any indirect, incidental, or consequential damages from the sale or use of the product. This disclaimer applies both during and after the term of the warranty.

King Controls disclaims liability for any implied warranties, including implied warranties of “merchantability” and “fitness for a specific purpose,” after the one year term of this warranty.

This warranty gives you specific legal rights, and you may also have other rights, which vary from state to state. Some states do not allow the exclusion or limitation of incidental or consequential damages, so the above limitation or exclusion may not apply to you. Some states do not allow limitations on how long an implied warranty lasts, so the above limitation may not apply to you.



11200 Hampshire Avenue South, Bloomington, MN 55438-2453
Phone: (800) 982-9920 Fax: (952) 922-8424

www.kingcontrols.com